

2023

Installation Instructions



Classic Line

Series 300 Minimalist Multi-Slide Door

Pocketing



Important Safety Information

Warning and Caution Information

WARNINGS

If warning is not heeded, may cause death or serious injury.

CAUTION

If precaution isn't taken, may cause minor or moderate injury.

NOTE:

Additional information that pertains to the installation.

NOTE: Read instructions front and back before beginning installation.

NOTE: Removal of Old Fenestration Products

Ensure that old fenestration products are removed and properly disposed. You may be able to recycle or donate removed glass and frames. For more information, check with your local recycling agency, the American Architectural Manufacturers Association, the U.S. Environmental Protection Agency, or the Building Materials Reuse Association to locate a nearby company or organization that accepts used windows and doors. To donate removed products, contact local nonprofits in need of building supplies, such as Habitat for Humanity.

NOTE: Homes and condominiums built before 1978 may have lead-based paint, which can pose serious health hazards during removal. Information and instruction regarding proper management of leadbased paint is available at www.epa.gov/lead.

NOTE: Installation Preparation

Multi-slide doors are custom-manufactured specific to each application. Prior to installation, it is important that you carefully review and understand the installation instructions and any drawings supplied. Western Window Systems' fenestration products should be installed only by experienced and qualified installation professionals. Failure to follow these instructions may result in poor performance, including but not limited to operation, security, and weatherproofing failures and may void Western Window Systems' express limited warranties.

NOTE: Product Handling and Storage

This is a finished product that must be protected before, during, and after installation to prevent damage to the glass, frame, finish, and hardware. The flush and water barrier sill tracks are supplied with individual track protectors that should be removed prior to assembly and installation of the frames. Upon completion of door installation, the track protectors can be selectively cut to length and re-installed to allow for specific panel operation or no panel operation.



Important Safety Information

NOTE: Door panels should be stored in a dry location that is protected from the elements. Wet packaging can cause damage to product finishes. If the packaging becomes wet, immediately replace it with dry packaging. Door panels should be stored and transported upside down. To avoid damage to the bottom rail extension, do not be drop or drag panels from the delivery truck.

NOTE: Components

The components supplied will vary depending on the configuration you are installing. Before proceeding with the installation, inspect the components to become familiar with them and confirm that there is no damage that will affect the appearance or performance of the installed product. Damaged or missing parts should be reported to your supplier immediately. If screens are included, they will be installed in a similar fashion as the glass panels.

NOTE: The rough opening must be waterproofed in accordance with AAMA Installation Masters standards and flashing and sealant manufacturer instructions and must meet local building codes.



Tools for Installation

- Level (6ft minimum recommended)
- Laser level (optional)
- #3 Philips screwdriver
- #2 Philips screwdriver
- Impact driver with #2 Philips bit
- Dow Corning 795 silicone or equal

Fasteners and Hardware

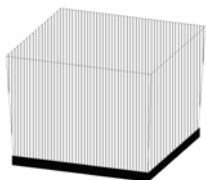
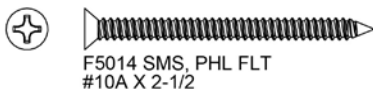

3/4" x 3/4" Pile Pad
W7560

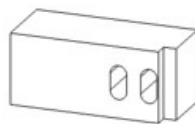

Flush Sill Pocket Post Spacer
H8700B

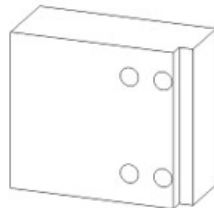

Water Leg Sill Pocket Post Spacer
H8701B

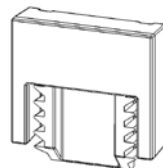

Interlock Bumper
H303B

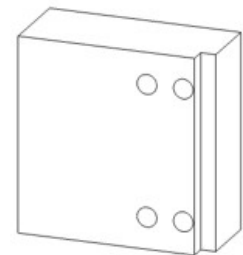

Head Pocket Post Spacer
H8702B

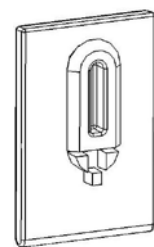

End Sweep
H301B



What To Know Before You Begin

NOTE: Read instructions front and back before beginning installation.

NOTE: Removal of Old Fenestration Products

Ensure that old fenestration products are removed and properly disposed. You may be able to recycle or donate removed glass and frames. For more information, check with your local recycling agency, the American Architectural Manufacturers Association, the U.S. Environmental Protection Agency, or the Building Materials Reuse Association to locate a nearby company or organization that accepts used windows and doors. To donate removed products, contact local nonprofits in need of building supplies, such as Habitat for Humanity.

NOTE: Homes and condominiums built before 1978 may have lead-based paint, which can pose serious health hazards during removal. Information and instruction regarding proper management of leadbased paint is available at www.epa.gov/lead.

NOTE: Installation Preparation

Multi-slide doors are custom-manufactured specific to each application. Prior to installation, it is important that you carefully review and understand the installation instructions and any drawings supplied. Western Window Systems' fenestration products should be installed only by experienced and qualified installation professionals. Failure to follow these instructions may result in poor performance, including but not limited to operation, security, and weatherproofing failures and may void Western Window Systems' express limited warranties.

NOTE: Product Handling and Storage

This is a finished product that must be protected before, during, and after installation to prevent damage to the glass, frame, finish, and hardware. The flush and water barrier sill tracks are supplied with individual track protectors that should be removed prior to assembly and installation of the frames. Upon completion of door installation, the track protectors can be selectively cut to length and re-installed to allow for specific panel operation or no panel operation.



What To Know Before You Begin

- Multi-slide pocket doors are custom manufactured specific to each application. Prior to installation, it is important that you carefully review and understand the installation instructions and shop drawings supplied. Failure to follow these instructions may result in poor performance including, but not limited to, operation, security, and weatherproofing.
- This is a finished product that must be protected before, during, and after installation to prevent damage to the glass, frame finish, and hardware.

NOTE: Door panels should be stored and transported upside down to avoid damage to the bottom rail extension.

- The flush and water barrier sill tracks are supplied with individual track protectors that should be removed prior to assembly and installation of the frames. Upon completion of door installation, the track protectors can be selectively cut to length and re-installed to allow for specific panel operation or no-panel operation.

NOTE: If screens are included, they will be installed similarly to the glass panel installation.

- The components supplied will vary depending on the configuration you are installing. Before proceeding with the installation, inspect the components to become familiar with them, and confirm there is no damage that will affect the appearance or performance of the installed product. Damaged or missing parts should be reported to your supplier **within 48 hours** of delivery.

NOTE: Components

The components supplied will vary depending on the configuration you are installing. Before proceeding with the installation, inspect the components to become familiar with them and confirm that there is no damage that will affect the appearance or performance of the installed product. Damaged or missing parts should be reported to your supplier immediately. If screens are included, they will be installed in a similar fashion as the glass panels.



Frame Components

Each door will have a head assembly and a threshold assembly.

Single pocket doors will have two post interlock frame members, and one or two lock jambs; two if screens are included.

Double pocket doors will have four post interlock frame members, but no lock jambs.

If the total frame width is greater than 336" (28'), the head and threshold assemblies will be supplied in two sections to be joined during installation.



Panel Components

Each door will have at least one active lead panel and one pocket panel.

Double pocket doors will also have an inactive lead panel and an additional pocket panel.

Active Panel

The active lead panel has the locking hardware and pull handles on the lead stile.

Inactive Panel

The inactive lead panel of double pocket doors has dummy handles on the lead stile.

Intermediate panels, if required, will have two interlock stiles. Pocket panels are the same as intermediates, except the interlock will be removed on the top 25% of the stile that meets the post interlock.



Frame Installation

NOTE: Refer to the shop drawings supplied and inspect the rough opening carefully to ensure it has been prepared correctly to accept the configuration and size you are installing.

NOTE: If the floor condition is wood, it must be protected with a sill pan or appropriate flashing prior to door frame installation.

NOTE: Check the floor to see that is flat and level. If the floor varies more than .0625" (1/16") per foot or a total of .25" (1/4") over the entire width of the opening, it must be corrected before proceeding with installation.

NOTE: One of the two walls forming the pocket(s), typically the interior side, must be left out until the frame installation is complete. * see link to pocket preparation on website

1. Position the threshold on the floor in the approximate location and make sure the inside edge of the threshold is properly aligned with the structure. If you have a flush sill, refer to the image below Fig. 1 to determine interior side.

NOTE: For doors where the threshold assembly is supplied in two sections, locate and install the left half first. The left half has an alignment tongue on the right end of the assembly. Make sure the two sections are completely together in the center and seal the joint with sealant.

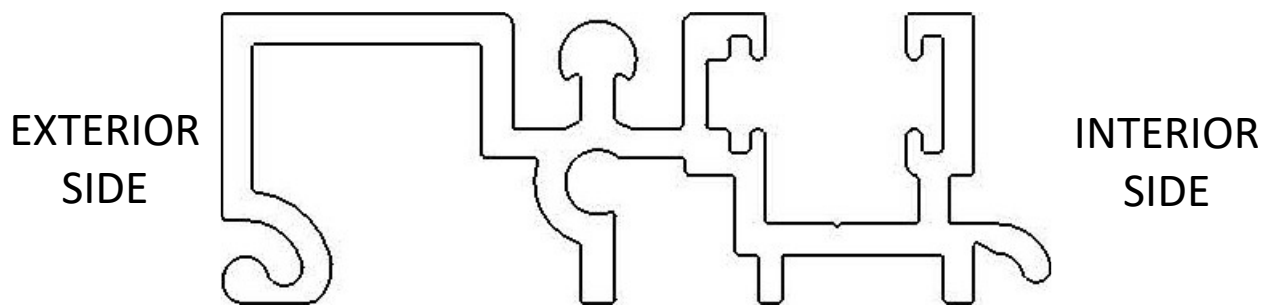

Fig. 1



Frame Installation

2. Locate the drilled holes on the outside face of the threshold. Position the exterior post interlock frame member(s) vertically so the holes in the threshold align with the holes in the post interlock(s). Observe the space between the exterior pocket walls and the nail fin of the post interlock.

NOTE: For single pocket doors, adjust the threshold assembly so the space between the pocket wall and the post interlock nail fin, perpendicular to the plan of the door, is equal to the space between the end of the threshold assembly and the adjacent wall where the lock jamb will be mounted. For double pocket doors, adjust the threshold assembly so the space between the pocket walls and post interlock nails fins is equal.

3. Inspect the threshold assembly where it meets the surface of the floor. Check for, and mark, any gaps that need to be filled or shimmed prior to final installation of the threshold. The final installation must result in the threshold being level and supported continuously for proper operation.
4. Once you are satisfied the threshold assembly is in the correct location, carefully inspect the header above to confirm the head assembly can be installed directly above it at the proper height. Mark the inside edge of the threshold assembly full length, and across each end sufficient to locate the inside corners. On the inside and outside, place an arrow on the floor at the midpoint between the two drilled holes where the post interlock frame members will attach.

NOTE: For single pocket doors, place at the inside and outside corners of the threshold on the lock jamb side.

5. Apply a .50" (1/2") wide by .50" (1/2") high bed of sealant on the floor along the exterior side of the mark, from arrow-to-jamb on single pocket doors or from arrow-to-arrow on double pocket doors. Apply additional sealant across the threshold perpendicular to the existing bed of sealant from arrow to arrow. Inspect sealant carefully to ensure a complete water barrier has been accomplished across the pocket opening(s), both at the lock jamb and along the outside edge of the mark indicating the inside edge of the threshold.

NOTE: Notice the factory applied sealant on the bottom side of the threshold between the points where the post interlock frame members will attach and at the lock jamb end. **It is very important that this sealant contact the sealant on the floor.**

NOTE: The threshold does not come with install holes and is meant to be adhered to the substrate with sealant only. This may not be adequate for configurations that have nominal-size panels larger than 4' x 10'. For larger panels, the use of anchor screws on the threshold may be required. **Refer to a PE licensed structural engineer for guidance.**



Frame Installation

- Using the marks on the floor, set the threshold assembly back in place. For doors where the threshold assembly is supplied in two sections, butter the end of the extreme inside track of the left section completely before setting the right section in place. This joint must be sealed completely.
- Inspect the opening header to confirm it is ready to receive the door head assembly and there is sufficient backing for anchoring. Based on the net frame height shown on the shop drawings, determine if additional material needs to be added to the header to minimize shimming. If the head assembly is supplied in two sections, you will need to back at the midpoint to support the splice.
- Using a plumb bob, project an adequate number of points onto the structure above to locate the head assembly directly above the threshold assembly. Carefully raise the head assembly into position and temporarily anchor using **#10 x 2.50" flat head screws** through the pre-drilled holes sufficient to hold it safely. For doors where the head assembly is supplied in two sections, locate and install the left half first. The left half will have an alignment tongue on the right end of the section. Make sure you bring the two completely together in the center.
- After the sill head and jambs are installed, install the interior and exterior pocket posts along with the appropriate pocket post spacers (see fig 3 and 4). Use the supplied **oval head #8 self-drilling screws** to attach the pocket posts to the head and sill. On the exterior side of the sill, apply silicone sealant to the area where the pocket post spacer will be contacting the sill, particularly in the groove of the sill. **Order steps with images on the next slide.**

NOTE: NO SPACER BLOCKS OR SCREWS WILL BE NEEDED ON DOORS ORDERED WITH A THINLINE SILL.

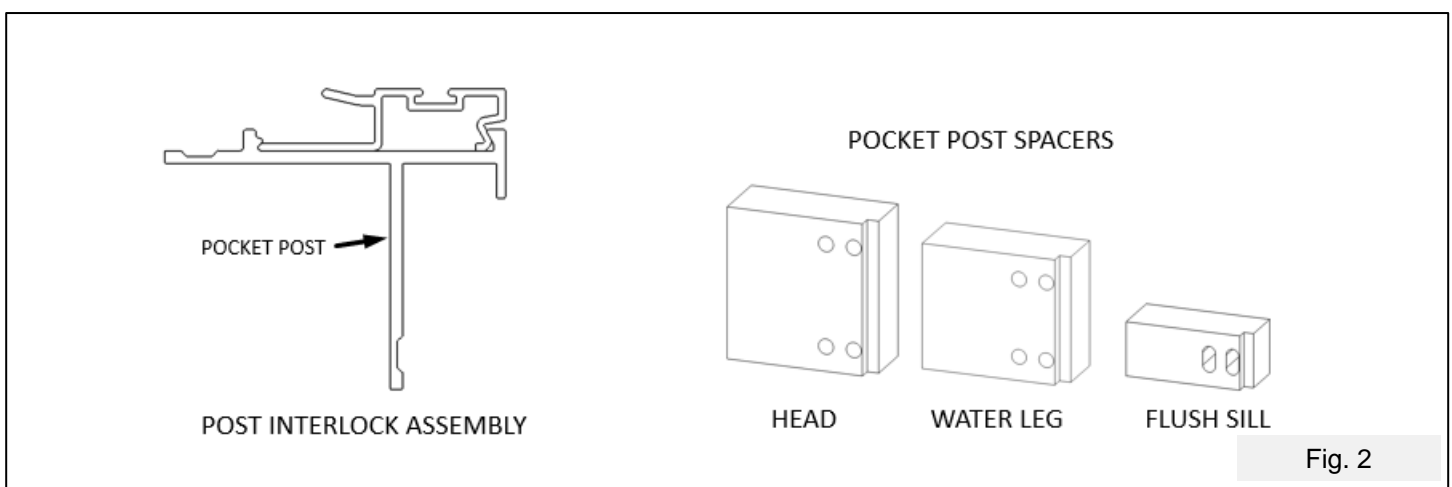



Frame Installation

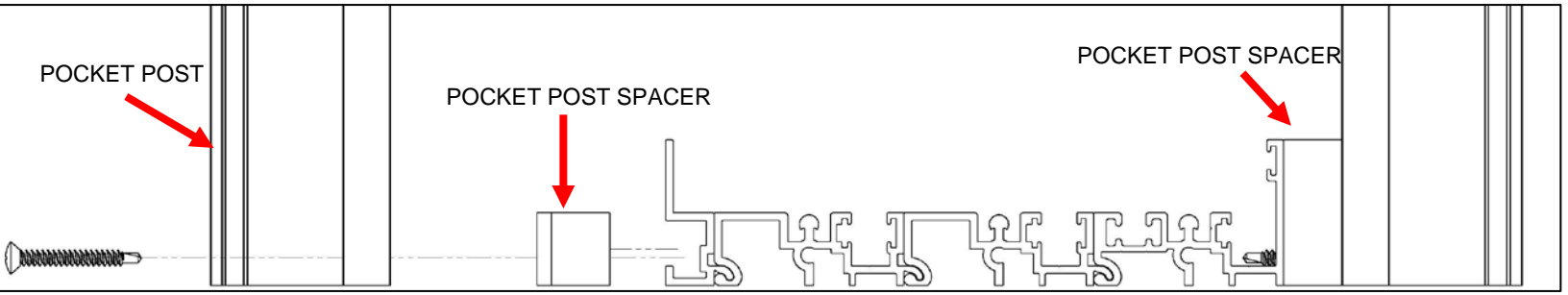
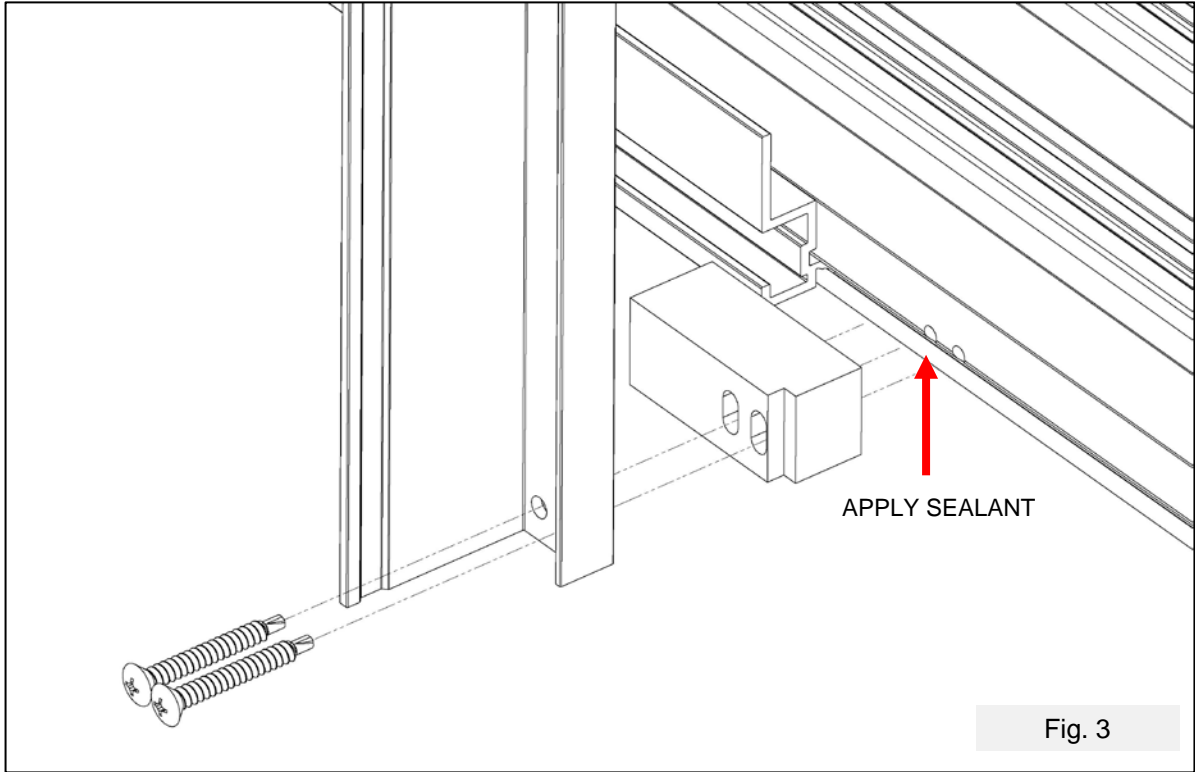

Fig. 4



Template not so fluid

10. Complete the installation of the post interlock frame member by shimming between the nail fins and the structure as required to ensure they are plumb. Check the dimension between the inside and outside members, from top to bottom, to ensure that they are parallel. Anchor the pocket post members using **supplied #10 x 2.50” stainless flat head screws**.

NOTE: Take care to make sure these screws sit flush with the nail-fin, as this may otherwise interfere with a later step of finishing the inside of the pocket with a pocket closure.

11. It is critical that the post interlock frame members are plumb and square to the head and threshold, and parallel to each other to ensure a smooth and quiet operation as the pocket panel interlock engages the post interlock.

12. Apply silicone sealant around perimeter of pocket post and pocket spacer, as well as between the exterior sill dam and the pocket post spacer (see Fig. 5).

NOTE: Applying too much sealant may affect your ability to install the snap-in post interlock later.

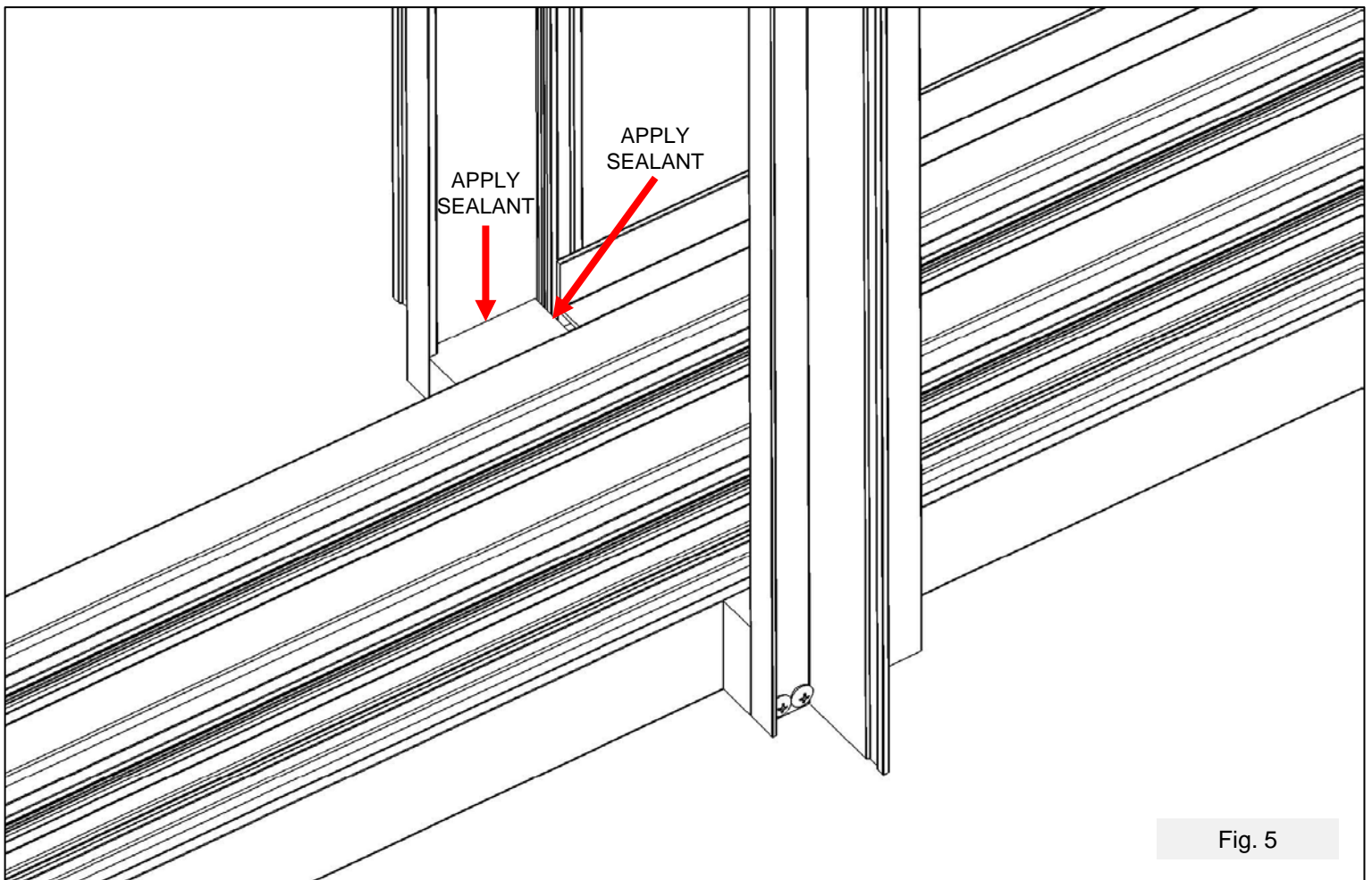

Fig. 5



Frame Installation

13. Complete the anchoring of the head assembly to ensure that it is flat, level and parallel with the threshold.
14. Before the panel installation, seal the vertical joint between the post interlock frame members and the face of the threshold, the horizontal joint between the post interlock and the top surface of the threshold, and the vertical joint between the post interlock and sill side plates with Dow Corning 795 silicone or equal.



Panel Installation

1. Locate and remove the black foam blocks from the head channels. The blocks are approximately 1" x 1" x 1.75" and there will be one in each channel. Set them aside temporarily, as they will be reinstalled when the panel installation is complete.
2. Each panel will be marked with the unit number, and a panel letter which is lettered from left to right as viewed from the exterior.
3. On the product label, each panel will be marked with the unit number and lettered by position: Lead (L), Intermediate * (I), Pocket Panel (P).

NOTE: The number of intermediate panels will vary by the configuration.

4. Locate the lead panel. If you are installing a double pocket door, there will be two lead panels. The active panel, the one that contains the lock mechanism, will be installed on the right of center as viewed from the exterior.

From the outside of the building, with the bottom rail vinyl to the outside, lean the top of the panel in and insert it into the head track that lines up with the lock jamb, and lower it onto the threshold. To avoid stripping the roller adjustment screws, lift the panel to remove the weight from the rollers. Using a #3 Philips screwdriver through the hole at the bottom of each stile, adjust the rollers to achieve approximately a .375" (3/8") gap from the bottom of stile to the top of the threshold. The interlock stile end sweeps will barely touch the top surface of the sill to reduce drag.

NOTE: For a thinline sill, cut off the small square peg on the backside of the end sweep, as shown below. This will allow the end sweep to be installed at the proper height.

5. Roll the panel towards the lock jamb to view the vertical gap between the panel and jamb. Make all rollers adjustments, so the gap is consistent from top to bottom.

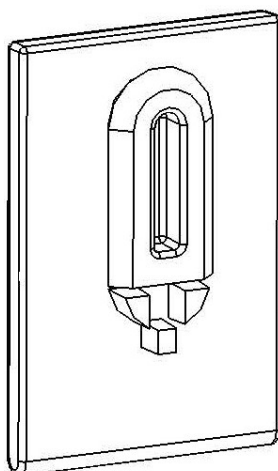

Standard Sill

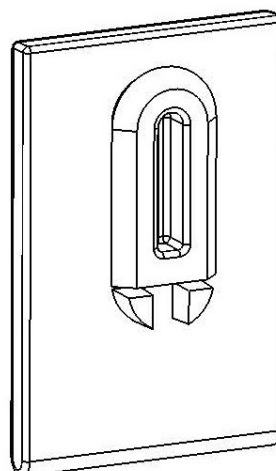

Thinline Sill

Fig. 6



Panel Installation

6. Locate the intermediate and pocket panels. From the outside of the building, with the bottom rail vinyl to the outside and the intermediate panel overlapping the lead panel, insert the top into the next head track and lower onto threshold. Repeat the same process with the remaining intermediate panels, ending with the pocket panel.
7. Ensure the panels are plumb to each other, as well as to the jamb and to the pocket post.

NOTE: Panels which are out of plumb could negatively affect the performance of the door system and may even not allow it to lock properly..

8. Install the supplied applied interlocker extrusion onto the pocket panel rear stile. The standard option of pocket stile is shown below. Figure 7 shows a horizontal cross section of the pocket stile with the applied interlock attached. (A narrower pocket stile may have been supplied with your door than what is shown below.)

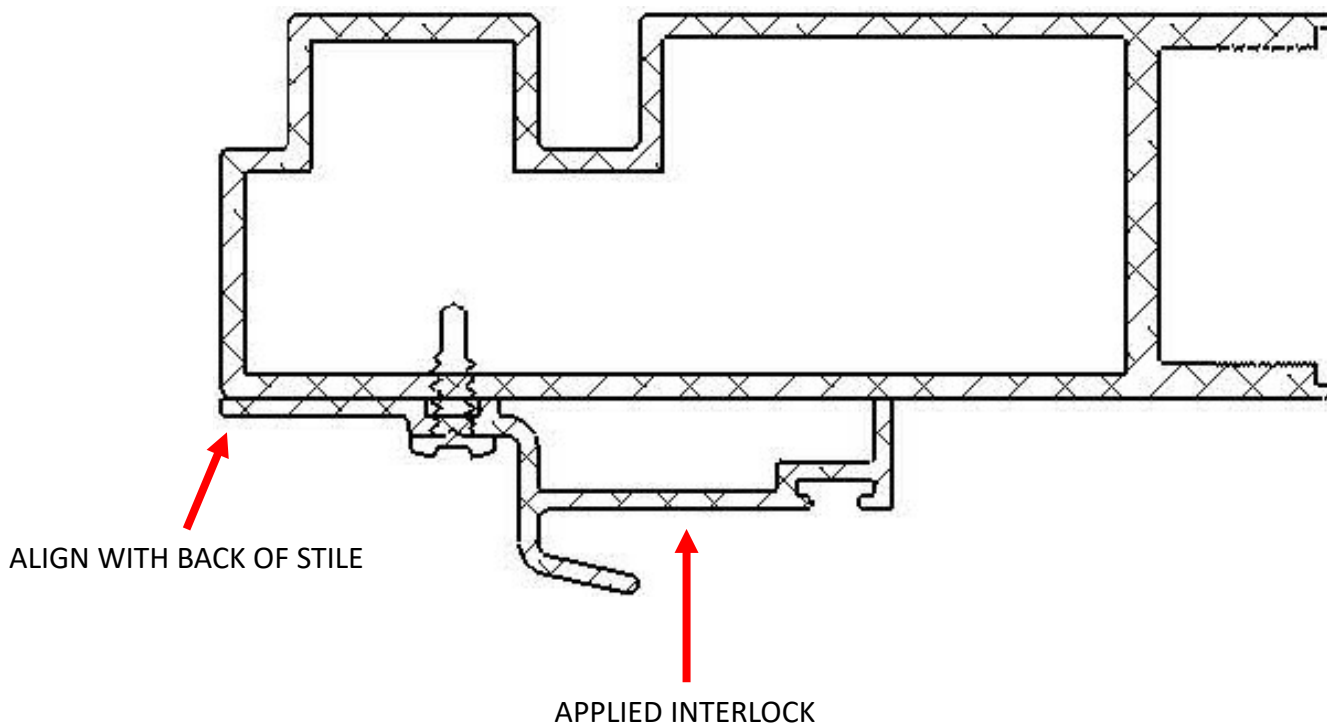

Fig. 7



Panel Installation

9. The applied interlock extrusion is cut slightly long to allow for perfect fitment with your installed system. The gap between the applied interlocker and the sill and head should be kept as small as possible allow for optimal air and water infiltration performance. You may have to consider a large enough gap at the head to account for settling.

NOTE: Do not exceed 1/8" gap between applied interlock and frame.

10. Once the applied interlocker is trimmed, install onto pocket stile using supplied #8 self-drilling pan head screws. Start with just two screws and roll the panel along its complete travel to ensure no contact will be made with the frame. Install all eight screws spaced evenly along the length of the stile.

There will be a pile supplied with each snap-in post interlocker. The pile for the exterior post interlocker may be used on the applied interlocker instead. If this is desired for better aesthetics, install this pile at this time and crimp in place by using a hammer and chisel to deform the t-slot to capture the pile from sliding down.

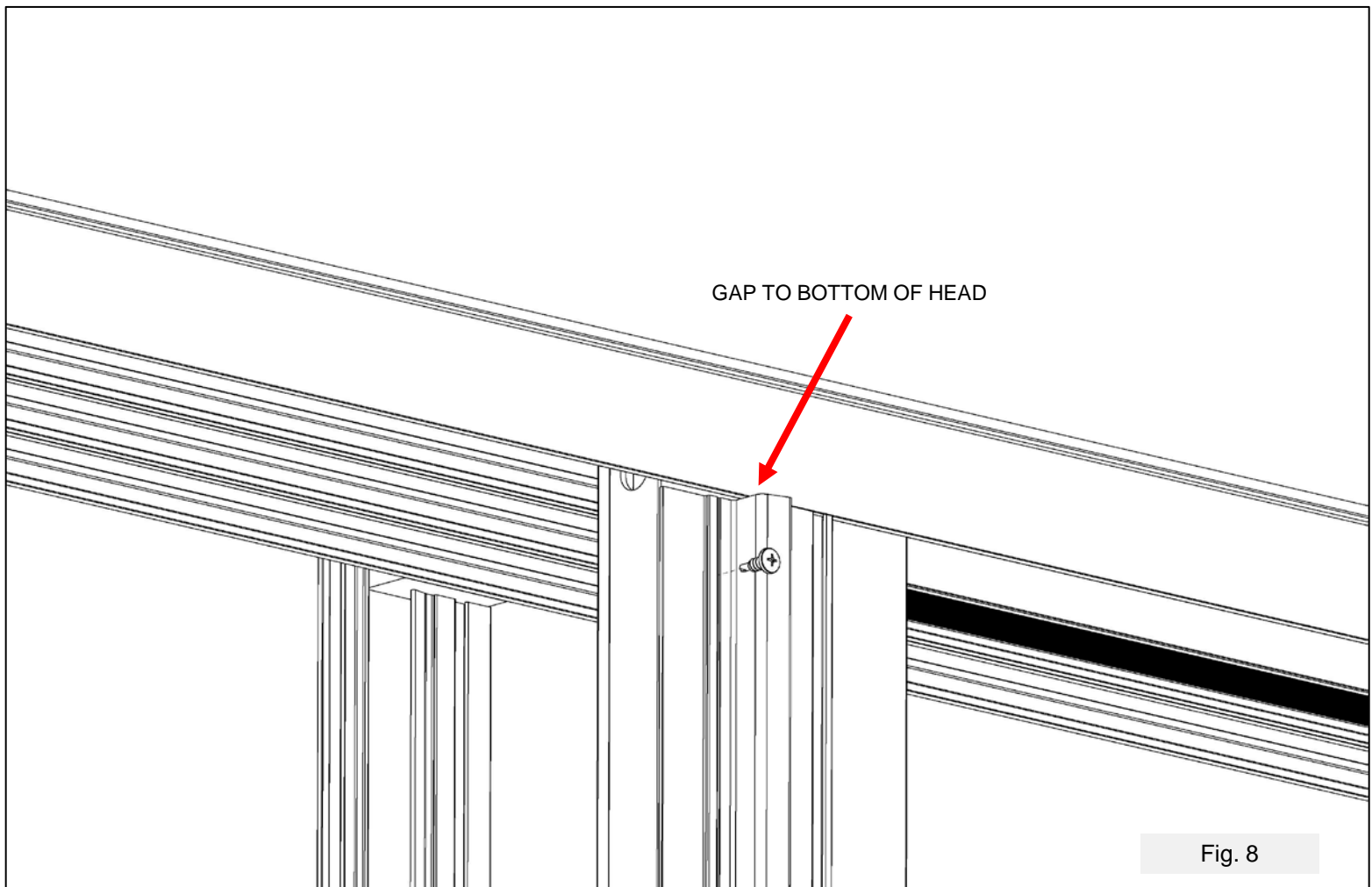

Fig. 8



Panel Installation

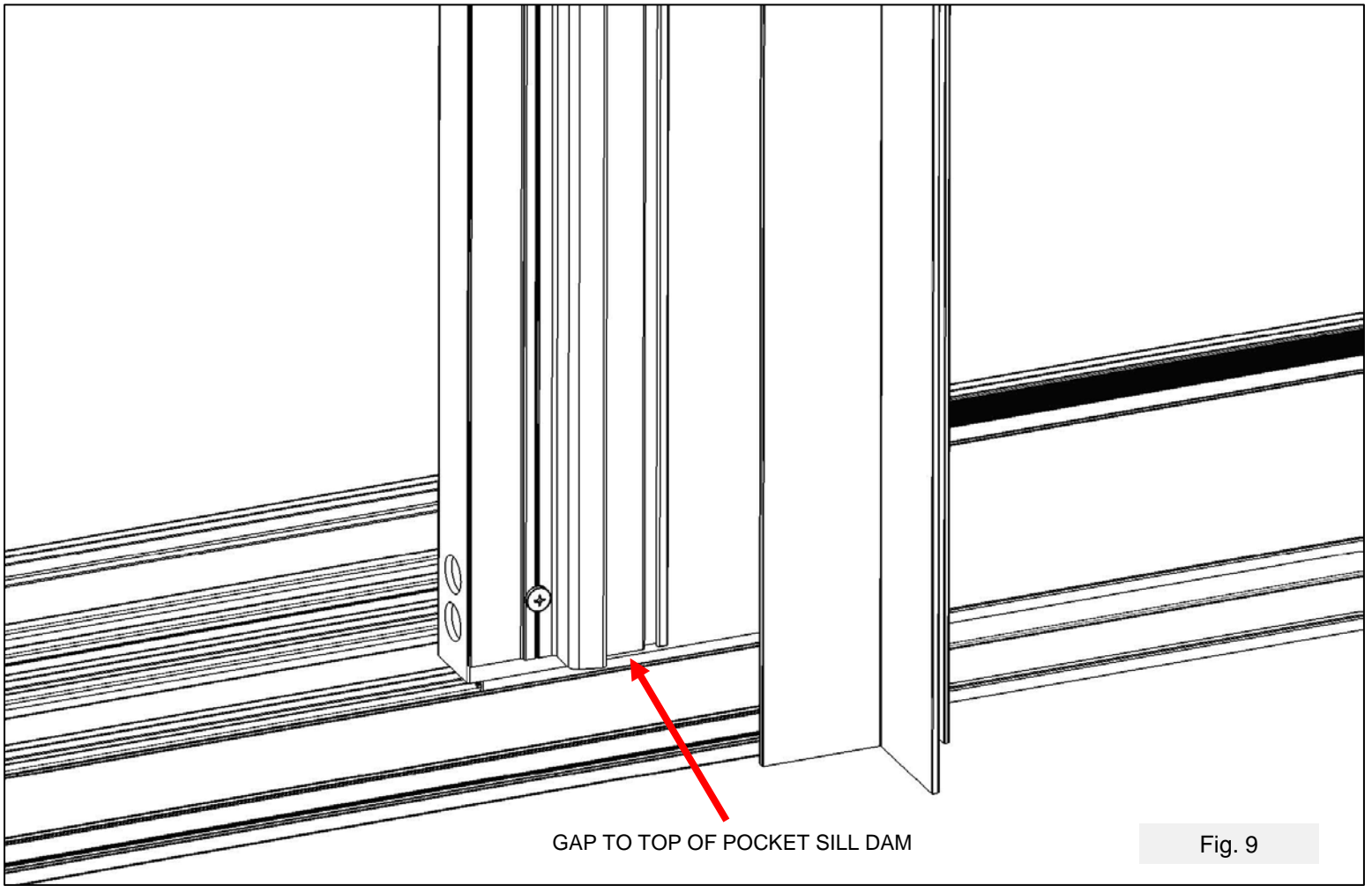

Fig. 9



Panel Installation

10. Install the interior snap-in post interlock. This may be done by hand or with the help of a non-marring mallet. The image below shows how to initially set the snap-in post interlock. Start from the top or bottom and “zipper” the post interlock on. The figure below shows how to start the part.

NOTE: The function of this post interlock on the interior is to minimize the gap between the pocket post and the lead panel when the door is fully opened. There should be a weatherstrip pile installed on the interior post interlock to further span the gap between the post and lead panel. Not including this pile may negatively impact the aesthetic of the door when fully open.

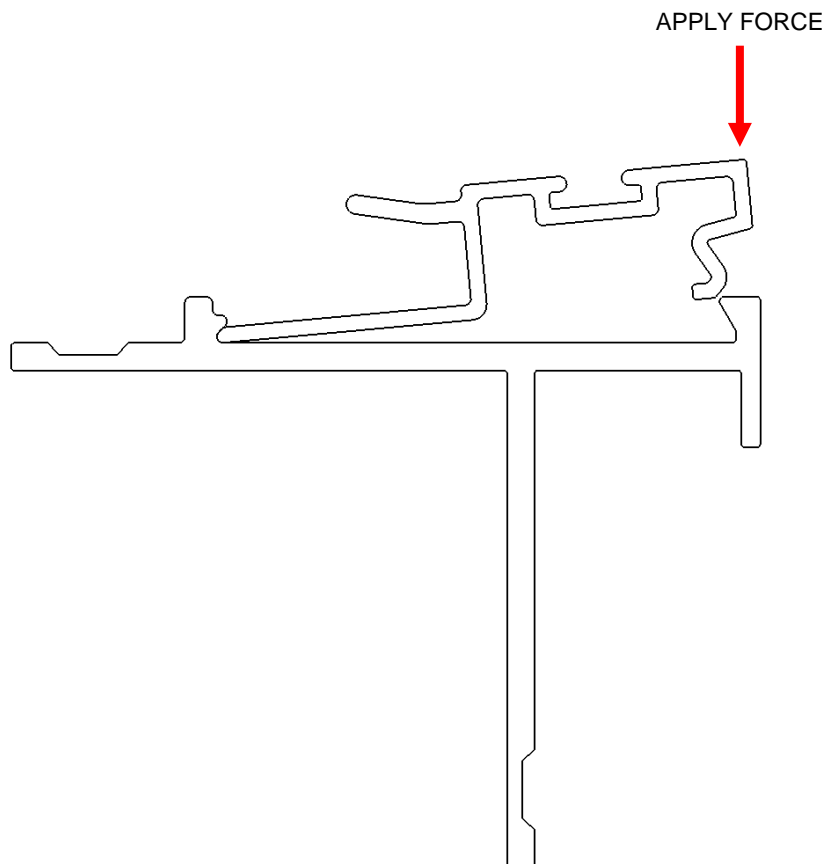

Fig. 10



Panel Installation

11. Locate the two pocket closure plates. These are made of hemmed sheet metal hemmed and will be taped to the pocket panel. One of these closures will be attached to the back of the pocket panel with the hemmed side facing the pocket.

Align the closure such that the gap between sill and head are even and that the interior edge minimizes the gap between the closure and post interlock. To minimize this gap on doors with a water leg sill, you will need to notch the bottom corner of the pocket closure to clear the water leg on the sill. You should also notch the bottom corner on the stile side to allow for future access to the roller adjustment screw.

Figure 11 shows this notching viewed from within the pocket. Anchor using #8 x .50" pan head self-tapping screws approximately 10" on center.

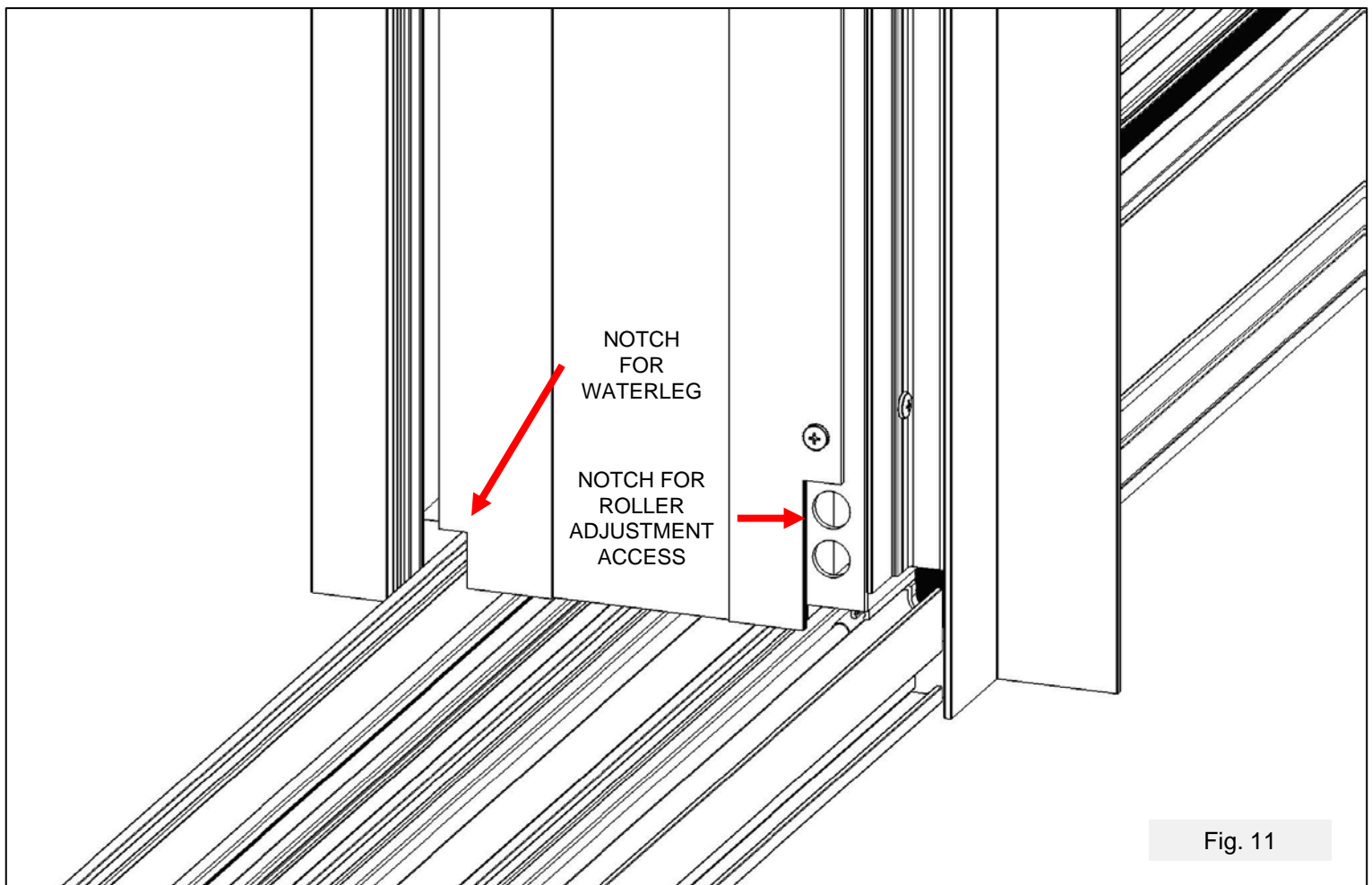



Panel Installation

12. The second closure will be used to finish the inside of the pocket that would otherwise be exposed due to the staggered stacking nature of the 300 series. How this closure is attached to the inside of the pocket is up to the installer. The pocket post provides a positive stop up to which the closure should be aligned to. This will allow the closure to hide the pocket post nail-fin screws. Use the horizontal cross section in figure 12 for reference.

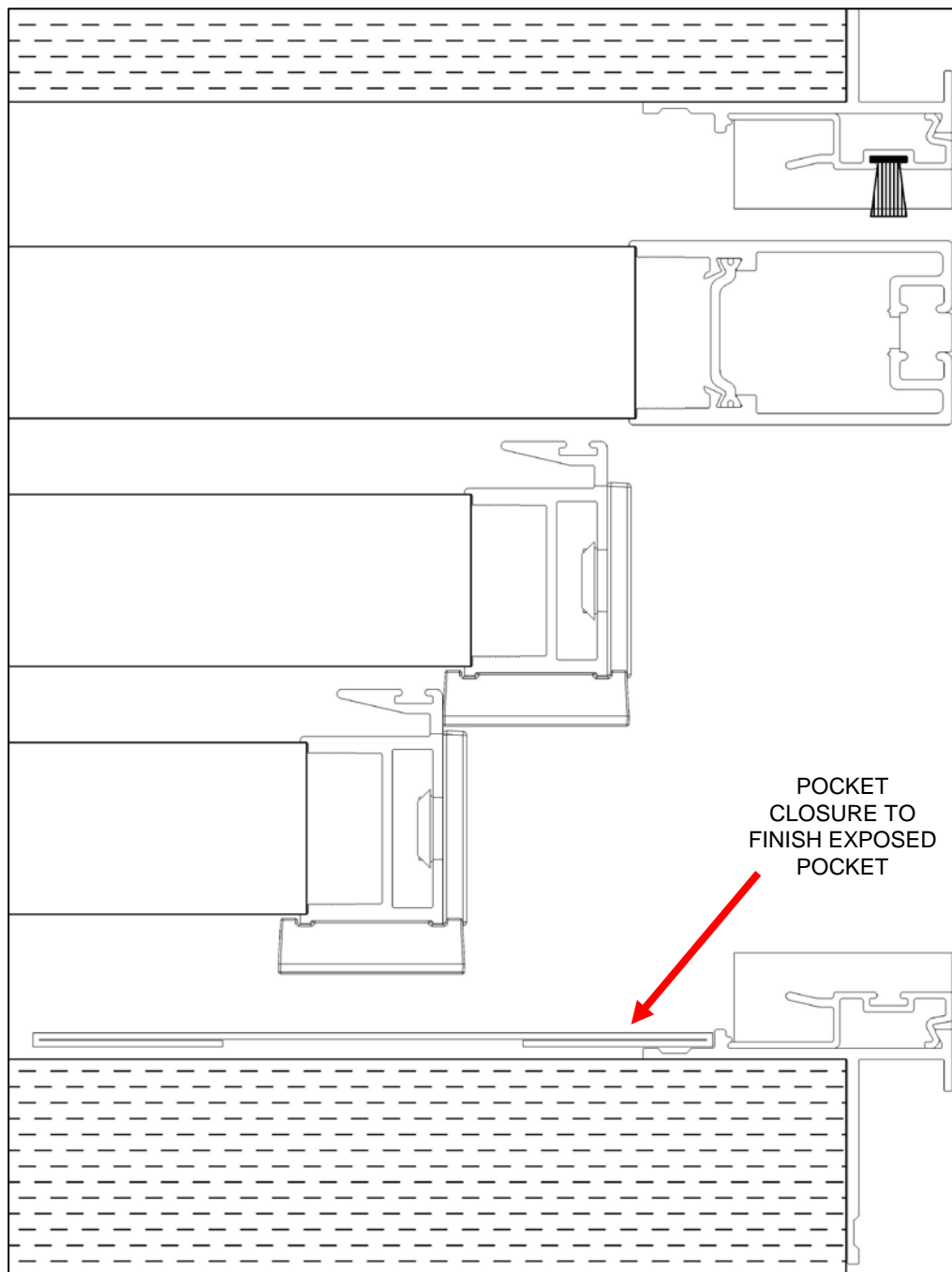

Fig. 12



Panel Installation

13. Roll the pocket panel partially or fully into the pocket to allow the installation of the exterior snap-in post interlock.
14. Install the supplied 3/4" x 3/4" adhesive-backed pile to the bottom of the exterior post interlock.

NOTE: The adhesive-backed pile is necessary for appropriate optimal air and water infiltration.

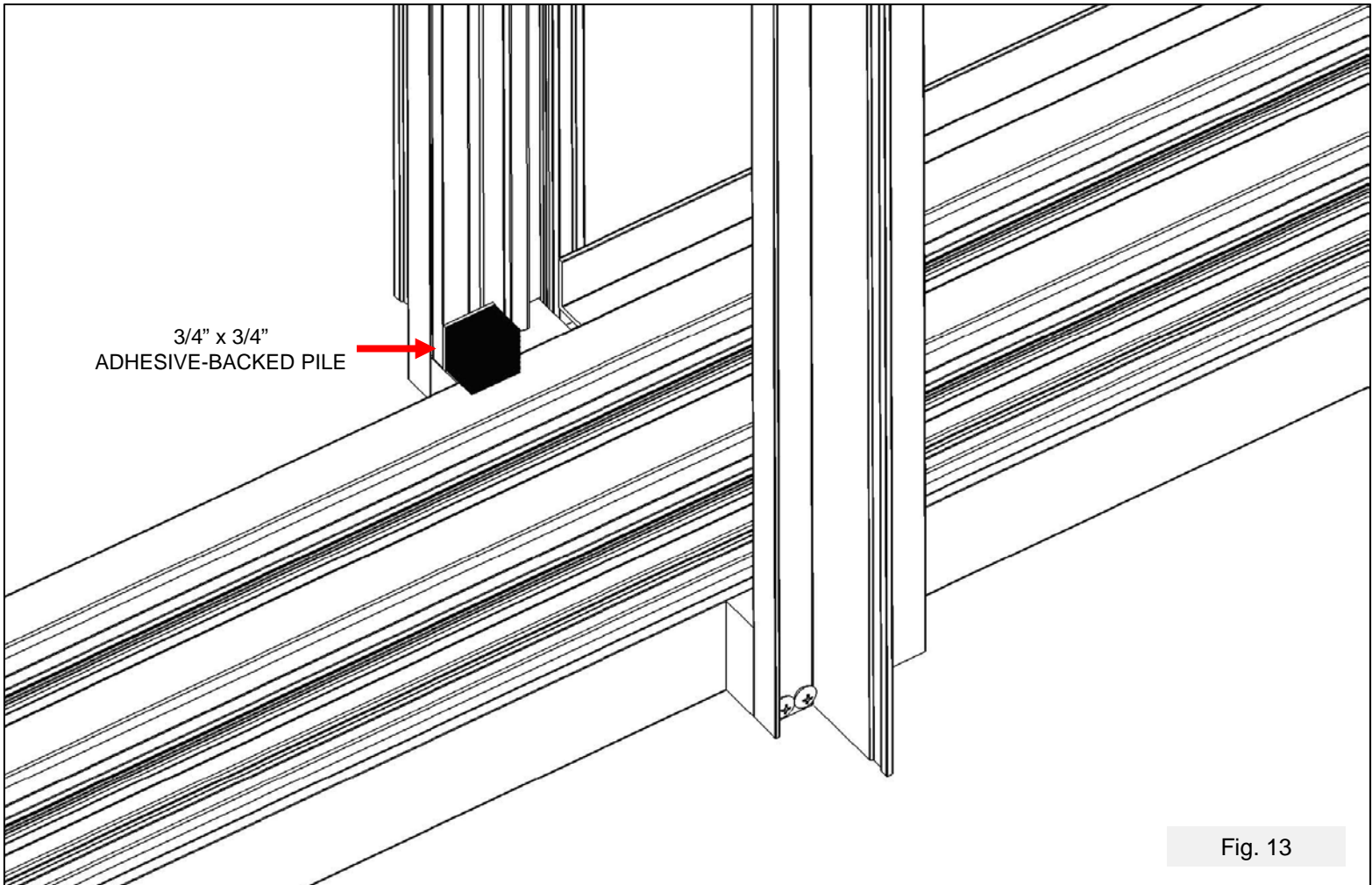



Panel Installation

15. Adjust the strike plate on the lock jamb by loosening the two machine screws and moving it up or down until the lock engages fully when actuated. To remove excessive slack, open the sliding panel and adjust the lock using the slotted adjusting screw in the center of the lock.
16. With the door in the fully closed position, from the exterior of the building, reinstall the black foam blocks (from instruction #1) up into the head channels against the top of each interlock stile to close the void above the panel.
17. Install the supplied interlocker bumpers at the top of each interlocker stile.

NOTE: When the panels are adjusted to the proper height, the interlock bumpers should not rub on the head, which would significantly affect rolling performance.

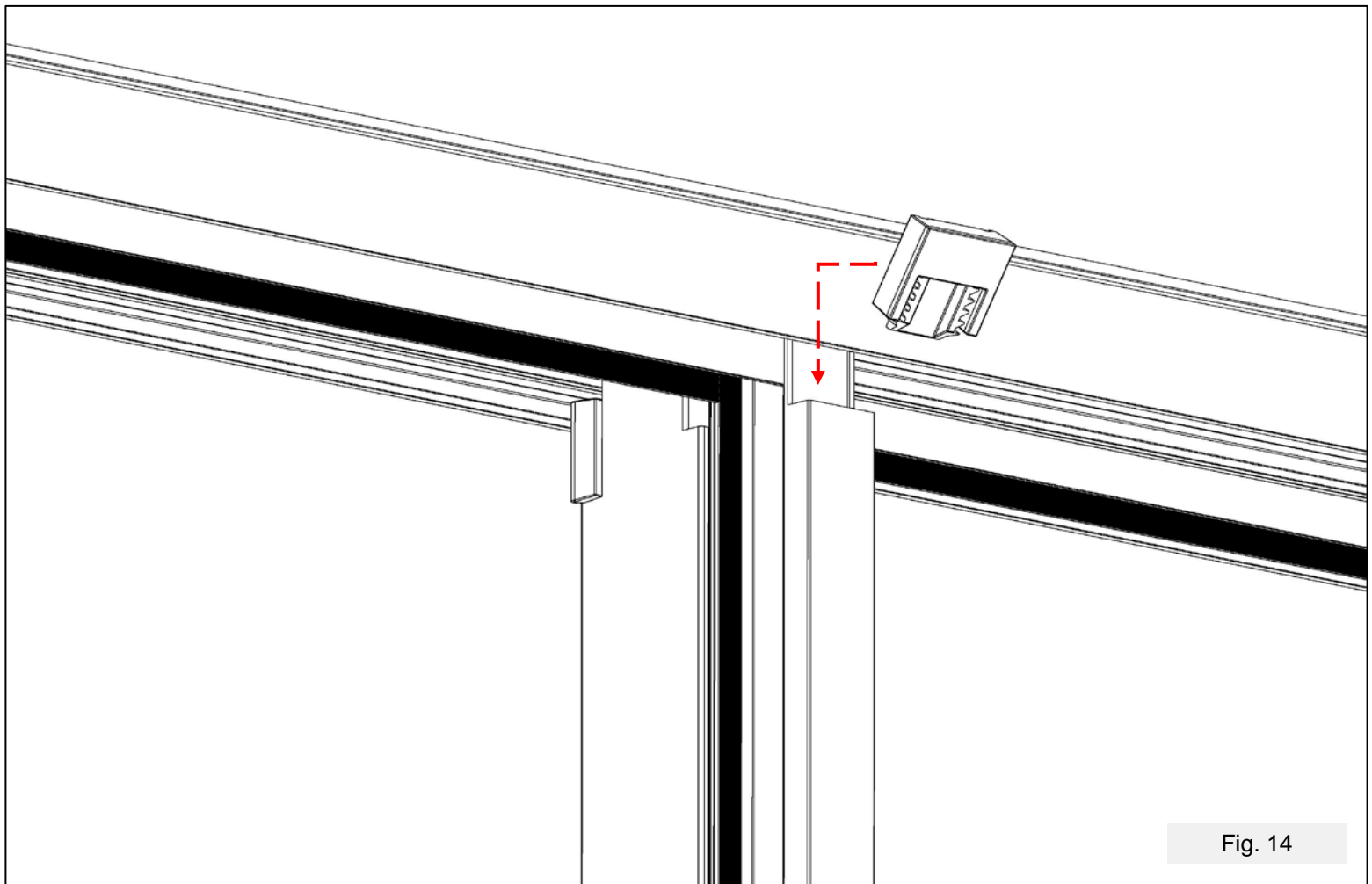

Fig. 14



Panel Installation

18. Seal the door frame to the structure as follows: Seal the interior side of the threshold to the door from the post interlock to the lock jamb on single pocket doors, or from the post interlock to post interlock on double pocket doors. Seal the exterior of the door frame at the head, jamb and post interlock members only. Do not seal the exterior of the threshold. The weep slots on the exterior of the threshold must remain open.
19. The door installation is complete.



Removing Post Interlock For Service

1. To remove the post interlock to remove the door panels, a special tool should be used to safely remove the post interlock without damaging the finish. Please contact your dealer or Western Window Systems service department to acquire this special tool.
2. Place pointed end of tool into the gap between the pocket post and post interlock. Starting from the top or bottom of the post, use a non-marring hammer to drive the tool into this gap, this releasing the snap feature. You may need to perform this a couple times in a zippering fashion until you can remove the post interlock by hand.

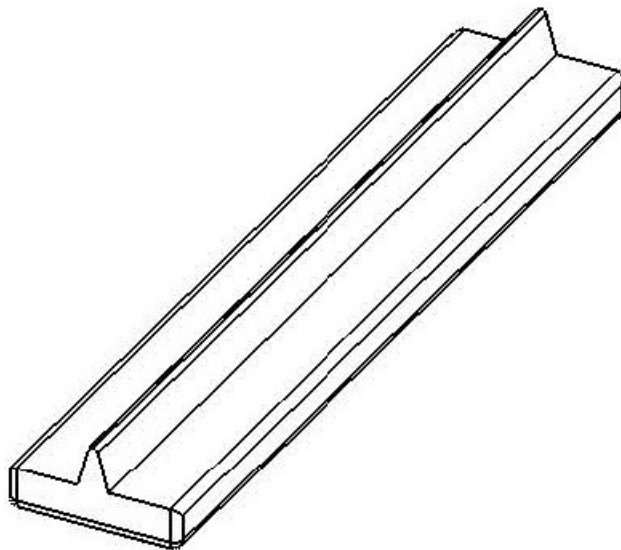

Fig. 15

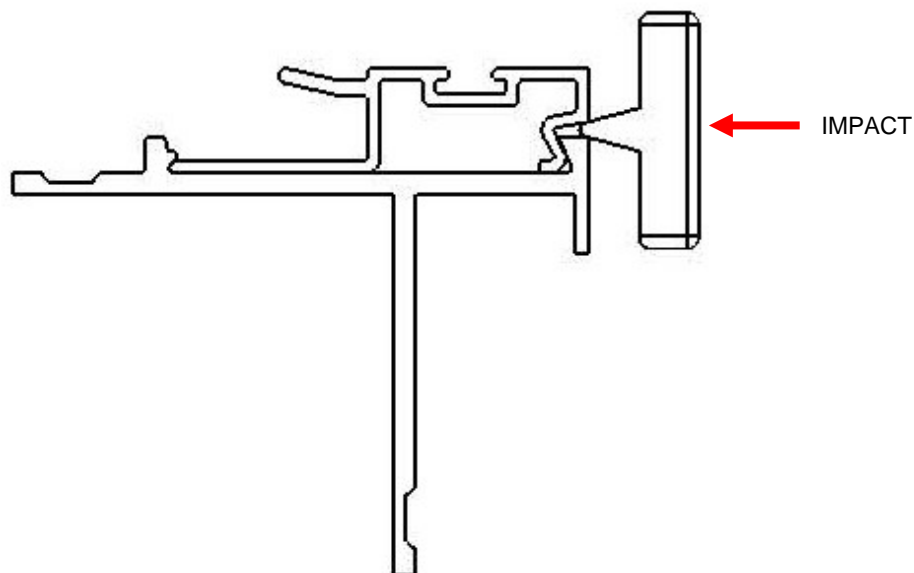

Fig. 16