

Series 7600s Multi-Slide Door

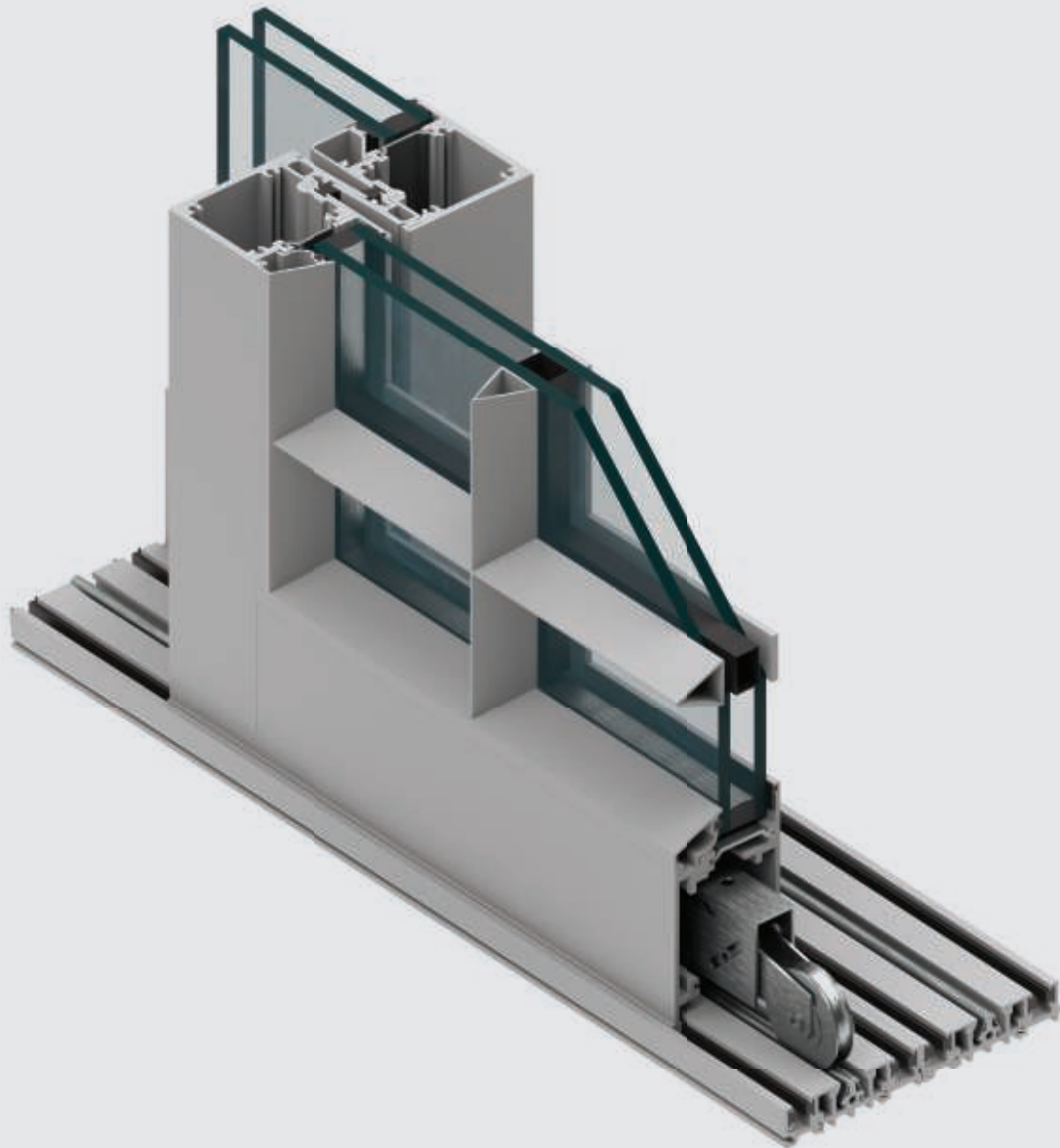

Build Better

SIMULATED STEEL LINE: Energy-smart, design-forward aluminum doors and windows that look like steel but are far more affordable.

Series 7600s Multi-Slide Door

The Series 7600s Multi-Slide Door features large, unobstructed rolling glass panels that stack or slide into pockets to create extra-wide openings for indoor-outdoor commercial and living spaces. Narrow sightlines, beveled glass stops, and coped muntin bars replicate the profiles of steel putty glazed windows used in historic buildings, universities, and commercial projects. The thermally broken aluminum frames feature high-quality anodized or painted finishes. The door can be easily integrated with simulated steel windows to form a consistent aesthetic throughout your project.

ENERGY EFFICIENCY

A .30 U-value for standard low-E, argon-filled dual-pane glass from Cardinal IG gives the door premium energy efficiency. It is compliant with California's rigorous Title 24 requirements and can be customized in a variety of panel counts, configurations, and wall depths. The aluminum frame and panels are thermally broken to reduce heat and cold transfer. NFRC labeling is included to comply with energy code requirements.

HARDWARE

The sealed stainless steel ball bearing rollers are AAMA-certified and include a standard 1.81" size. Our optional Quad-Zilla roller is capable of handling extreme panel sizes and heavy glass types. A hidden stainless steel multi-point lock secures the sliding panels.

OPTIONS

Sill options include a 2" or 2.6" water barrier height offering design flexibility with varying performance ratings; a flush sill, which is best when ease of entry is more important than keeping out the elements; and the Thinline sill, which is ideal in situations where the continuation of flooring from the inside to the outside appears seamless. Handle options include a flush-mounted handle, which allows panels to slide past each other and stack flush or into a pocket. The contemporary handle features a minimal one-piece design and comfortable grip. Both handles have an optional keyed cylinder.

FINISHES AND COLORS

Finishes are available in-stock or as designer selections, and they can be customized to match nearly any color. Split finishes are available in many combinations. Bronze Anodized and Satin Anodized come standard with a Class 1 coating thickness for increased smoothness and durability. Our designer colors include a high-quality paint finish that conforms to a minimum rating of AAMA-2605, currently the highest rating for organic finishes.

PERFORMANCE

Frame Depth	2.87" Per Track
AAMA Product Designation (AAMA/WDMA/CSA101/I.S.2/A440 Designation)	LC-PG50-144x120-SD
Test Configuration	144" x 120" XXO
Air Infiltration (Per ASTM E 283)	.24 cfm/sf @1.57 psf
CSA A440 Air	A2
Water Resistance (Per ASTM E 547)	8.0 psf
Uniform Load Deflection (Per ASTM E 330)	50 psf
Uniform Load Structural (Per ASTM E 330)	75 psf
Forced Entry Resistance	ASTM F842 Type B Grade 10
U-Factor (Per NFRC 100)*	0.30
CR (Per NFRC 500)*	57
CRF Frame (Per AAMA 1503)	69

Actual values may vary depending on product specifications and configuration.
*Glass Makeup = 1" OA E366/Argon/Clear

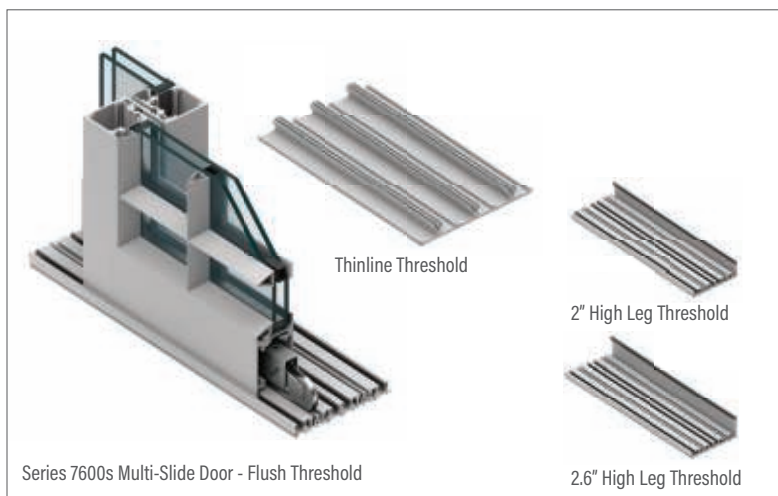

Series 7600s Multi-Slide Door

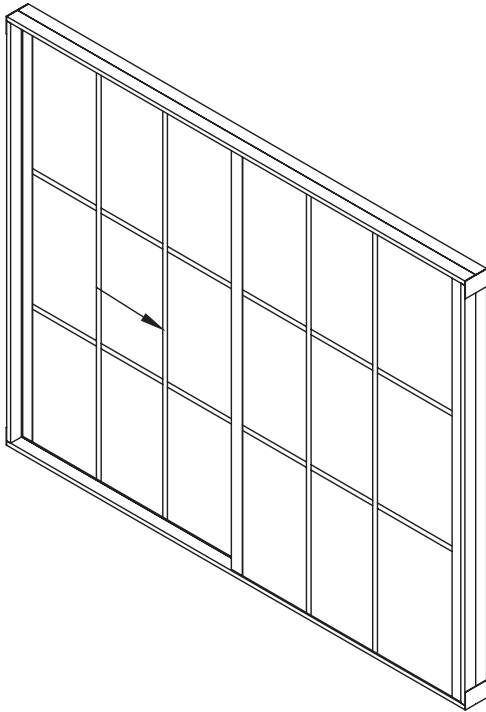

Simulated Steel Features

- .30 U-value for standard low-E, argon-filled dual-pane glass
- All-climate coated or high-performance glass from Cardinal IG
- Glass can be customized and includes options such as laminated glass, solar- and glare-control glass, enhanced winter performance glass, and low-maintenance glass
- Pre-applied Cardinal Preserve film protects glass during installation
- Performance-rated at DP50
- Available in sizes up to 15 feet in most markets
- 2.9" interlock stile
- Pocketing, non-pocketing, bi-parting, and 90-degree configurations
- Certified by AAMA
- Energy Star-qualified options
- Sealed stainless steel ball bearing rollers
- Quad-Zilla roller for extreme sizes and heavy glass types
- Water barrier, flush, and thinline sill options
- Premium or flush-mounted handle
- Interlocking track design
- Concealed locking system
- Aluminum frame panel screen
- In-stock, designer, split, and custom finishes
- System automation (third party)
- Title 24 compliant (California)

Series 7600s Multi-Slide Door

