



**Series 7630** Installation Instructions  
Window Wall (Equal Leg Frame and Nail Fin)

# Things to Know Before You Start

## Removal of Old Fenestration Products

Ensure that any old fenestration products are removed and properly disposed. You may be able to recycle or donate removed glass and frames. For more information, check with your local recycling agency, the American Architectural Manufacturers Association, the U.S. Environmental Protection Agency, or the Building Materials Reuse Association to locate a nearby company or organization that accepts used windows and doors. To donate removed products, contact local nonprofits in need of building supplies, such as Habitat for Humanity.

**Please note:** Homes and condominiums built before 1978 may have lead-based paint, which can pose serious health hazards during removal. Information and instruction regarding proper management of lead-based paint is available at [www.epa.gov/lead](http://www.epa.gov/lead).

## Installation Preparation

Window walls are manufactured specific to each application. Prior to installation, it is important that you carefully review and understand the installation instructions and any drawings supplied. Western Window Systems' fenestration products should be installed only by experienced and qualified installation professionals. Failure to follow these instructions may result in poor performance including but not limited to operation, security, and weatherproofing failures and may void Western Window Systems' express limited warranties.

Verify that the window is the correct size and unit number, marked on the opening.

If you are bridging two or more installed mull windows, also see mull sealing instructions on p. 5.

## Product Handling and Storage

This is a finished product that must be protected before, during, and after installation to prevent damage to the glass, frame, finish, and hardware. Upon completion of window installation, the windows should be masked off and protected from any chemical exposure such as paint or mortar/ stucco.

**The window should be stored in a dry location that is protected from the elements. Wet packaging can cause damage to product finishes. If the packaging becomes wet, immediately replace it with dry packaging. To avoid damage, windows should be stored and transported on a flat, even surface and should not be dropped or dragged from the delivery truck.**

## Components

The components supplied will vary depending on the configuration you are installing. Before proceeding with the installation, inspect the components to become familiar with them and confirm that there is no damage that will affect the appearance or performance of the installed product. Damaged or missing parts should be reported to your supplier immediately. If screens are included, they will be installed in a similar fashion as the glass panels.

## Other Tools and Materials Necessary for Installation

1. Flashing membrane
2. Sealant compatible with the flashing membrane
3. #10 – 2½" flat-head screws for block frame installation
4. 1¼" pan-head self-taping screws for nail fin installation

# Things to Know Before You Start

5. Levels of various sizes or a laser Level
6. Pry bar
7. Dead-blow rubber mallet
8. Glazing roller for vinyl
9. Shims. Except in circumstances where a particular shim type is specified by applicable building codes, either wedge shims or horseshoe shims may be used. Shimming must be even across the window unit. Each shim must be long enough to cover the full width of the window frame from front to back.

## Weatherproofing

Rough openings must be waterproofed in accordance with AAMA Installation Masters standards and flashing and sealant manufacturer instructions, and they must meet all local building codes. Please refer to the videos provided online at: <https://www.westernwindowsystems.com/professionals/dealer/>

## Frame Installation

1. **Frame Components:** Each window will have a head assembly, a sill, and a left and right jamb assembly (See Fig. 1).

Fig. 1

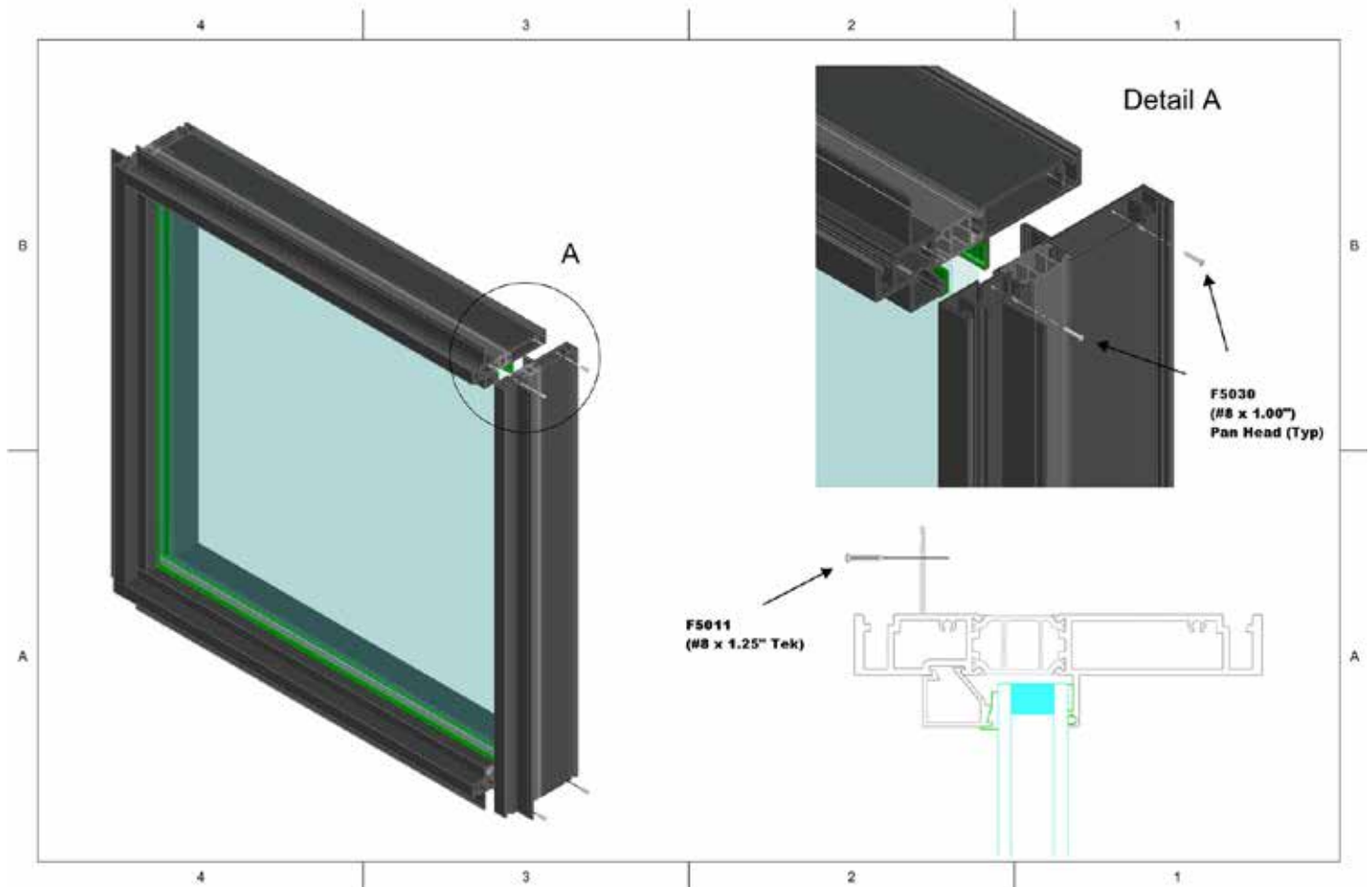

# Nail Fin Instructions

1. Refer to the CADD drawings supplied or order acknowledgement and inspect the rough opening carefully to ensure that it has been prepared correctly to accept the configuration and size you are installing.
2. Verify that the opening is the appropriate size to accept the product and is square, plumb, and level.
3. Apply a continuous  $\frac{3}{8}$ " bead of sealant to the interior face of the nail fin and place the window into the flashed opening. The nail-on flange should make full contact with the opening.
4. Check that the unit is square, plumb, and level, starting with the sill, making sure it is shimmed even from jamb to jamb. Then level and plumb the jambs using shims to hold in place at the top and bottom.
5. Secure all nail flanges to the structure using self-taping screws at 12" on center. The first screw should be 3 inches from the corner.
6. All screws and fin edges should be sealed when anchoring is complete.
7. Re-verify that the unit is square, plumb, and level.

**Fig. 2**

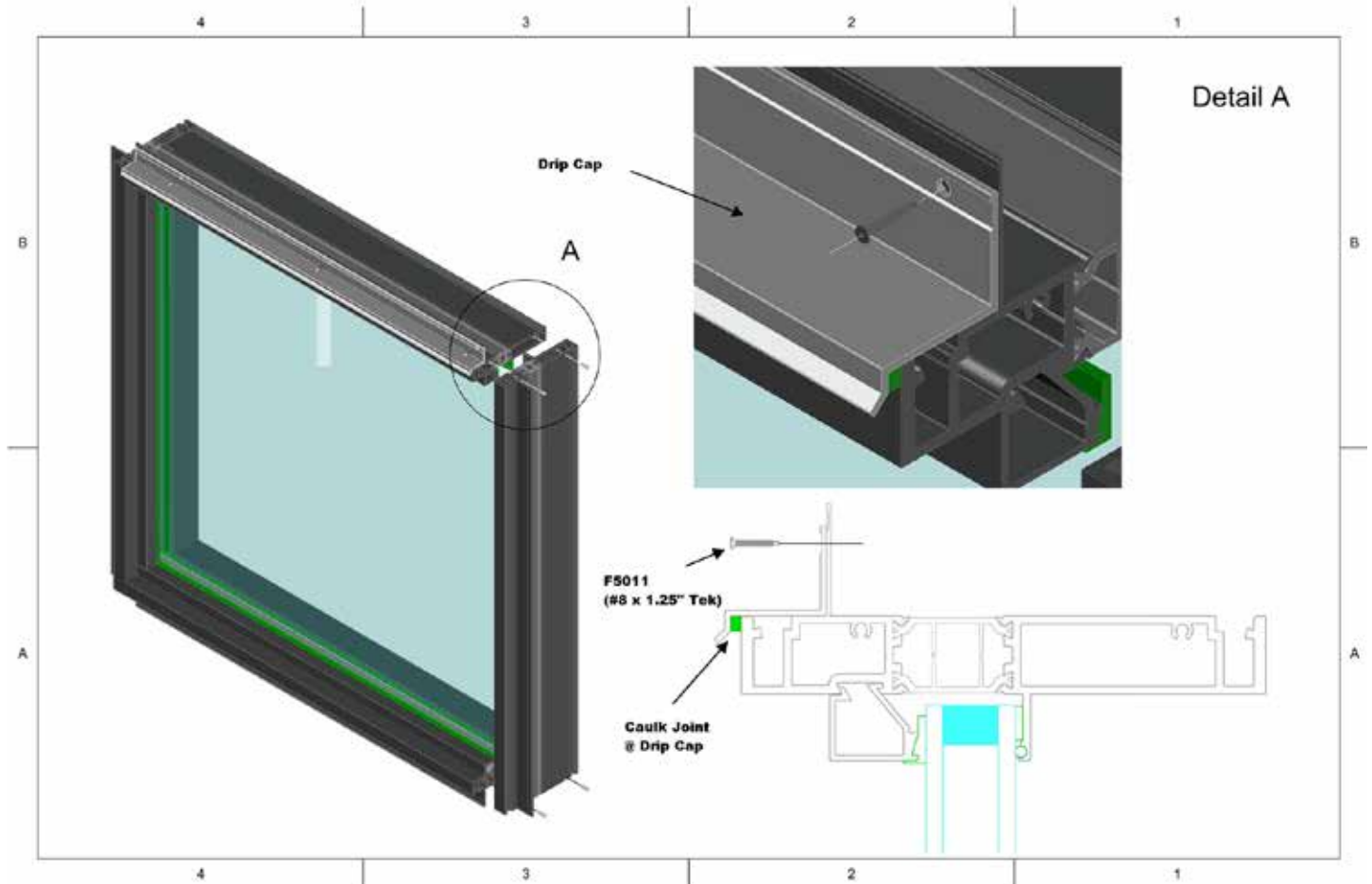

# Equal Leg Instructions

1. Apply a  $\frac{5}{8}$ " bead of sealant across the width of the opening and 4" up both jambs. Locate  $2\frac{1}{2}$ " from the outermost frame point.
2. Remove jamb stops and drill  $\frac{3}{16}$ " holes in jambs at maximum of 18" on center, with the first screw 6" from the corner of the frame. Countersink holes so that the head of the screw will not interfere with replacement of stops. (Recommend screw type: #10 –  $2\frac{1}{2}$ " flat-head.)
3. Position the window near the opening.
4. Place the window into the opening and hold it in place with shims.
5. Verify that the window is square, plumb, and level using shims. Shimming is required at all fastener locations. If using wedge shims, make sure the shims are inserted from the interior and exterior in order to provide a solid, flat surface against the window.
6. Pump the sealant into the installation holes, then run the installation screws through the prepared holes.
7. Replace the glazing stops and roll the glazing vinyl back in place using a glazing roller.
8. Trim excess shims.
9. Backer-rod and perimeter-caulk the perimeter frame to the waterproofing on the exterior.

Fig. 3

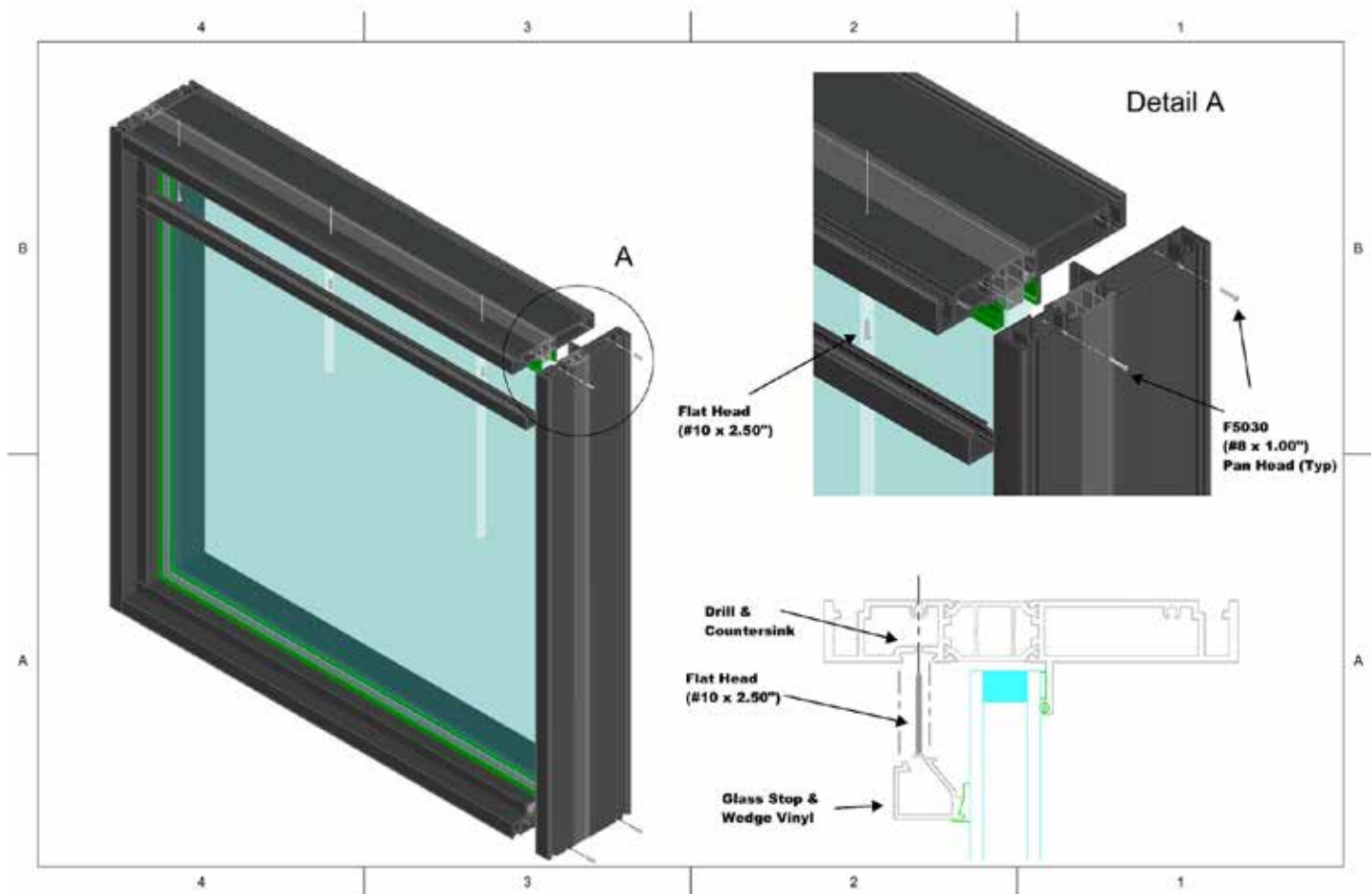

# Mull Sealing Instructions

Follow these instructions to bridge two or more installed mull windows.

## Things To Know Before You Start:

1. Sealants should be compatible with the building envelope's waterproofing membrane.
2. Always use drip caps at the head for vertical mull windows with a nail fin.
3. Order drip caps with the window order. These will ship loose.
4. The E7661B mull bar is shipped loose. You will have two pieces per field mull.

## Equal Leg Application Instructions

1. Fill mull pocket with 100 percent silicone.
2. Insert mull bar E7661B into the mull pocket.
3. Fill the opposite mull pocket with 100 percent silicone.
4. Using quick clamps, slide both window sections together until the mull bar is completely hidden, leaving an even reveal from top to bottom.
5. Using shims on the interior, shim behind the head, the sill, and wherever needed in the center to push and hold both sections tightly together. Trim any excess shims.

Fig. 4

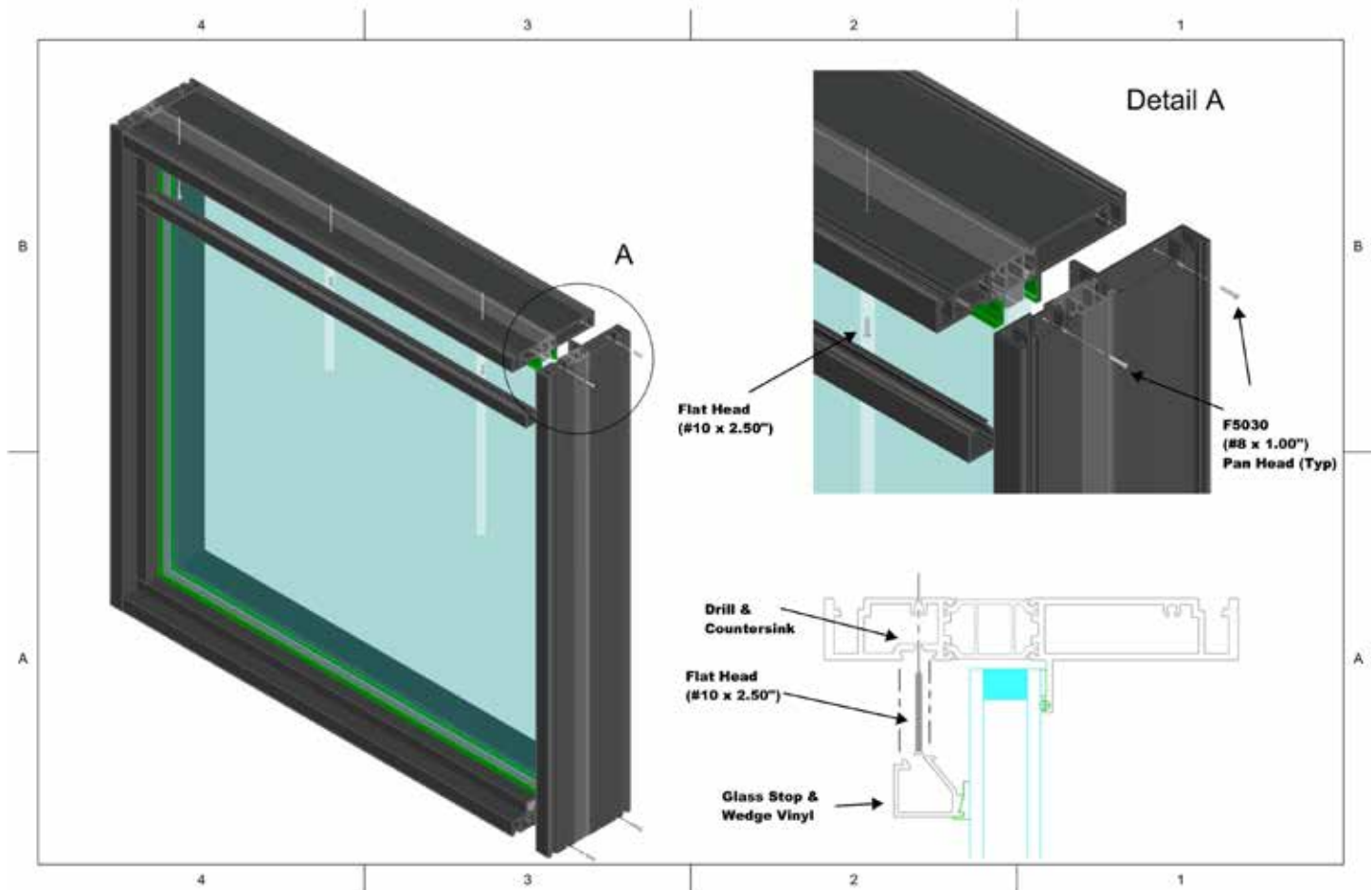

# Nail Fin Application Instructions

1. Fill the mull pocket with 100 percent silicone.
2. Insert mull bar E7661B into the mull pocket.
3. Fill the opposite mull pocket with 100 percent silicone.
4. Using quick clamps, slide both window sections together until the mull bar is completely hidden, leaving an even reveal from top to bottom.
5. Using shims on the interior, shim behind the head, the jambs and wherever needed in the center to push and hold both sections tightly together. Trim any excess shims.
6. Squeeze and insert foam backer rod into the mullion gap between the extrusions. Push the block evenly in place until it rests  $\frac{1}{4}$ " to  $\frac{3}{8}$ " inside the gap. This will serve as backing for the sealant.
7. Fill the void area solid with sealant. Flatten and smooth with a putty knife.
8. Apply a sealant bead across nail fin gap.
9. Orient and press the mull cover into place. The mull cover will act as a bridge from nail fin to nail fin.
10. Seal around the edges of the mull cover and tool sealant until all voids are filled. Appearance should be smooth and flat.
11. Proceed with final waterproofing membrane applied over the nail fin.
- 12. The bridge of installed mull windows is complete.**

Fig. 5

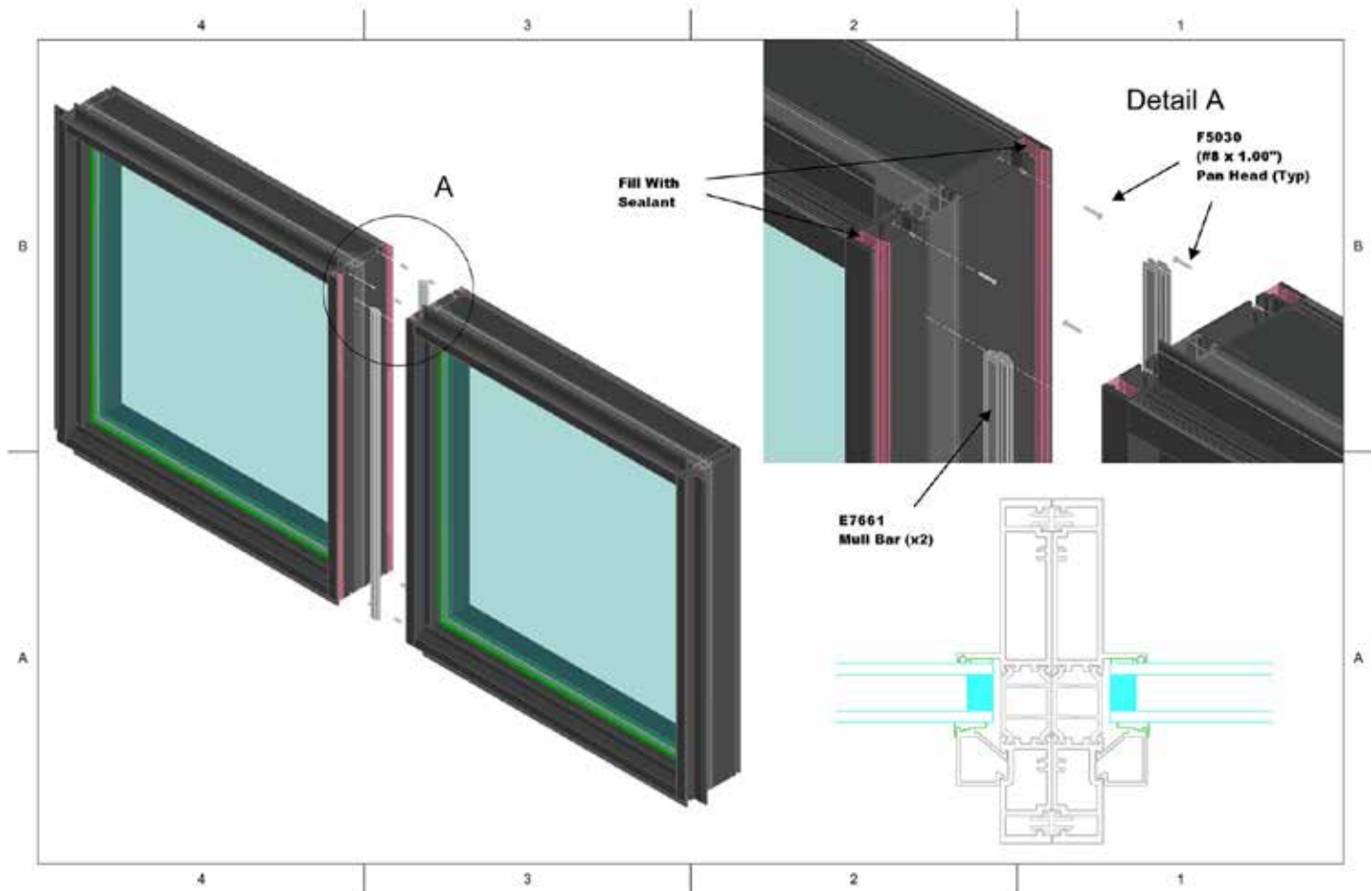

# Nail Fin Application Instructions

Fig. 6

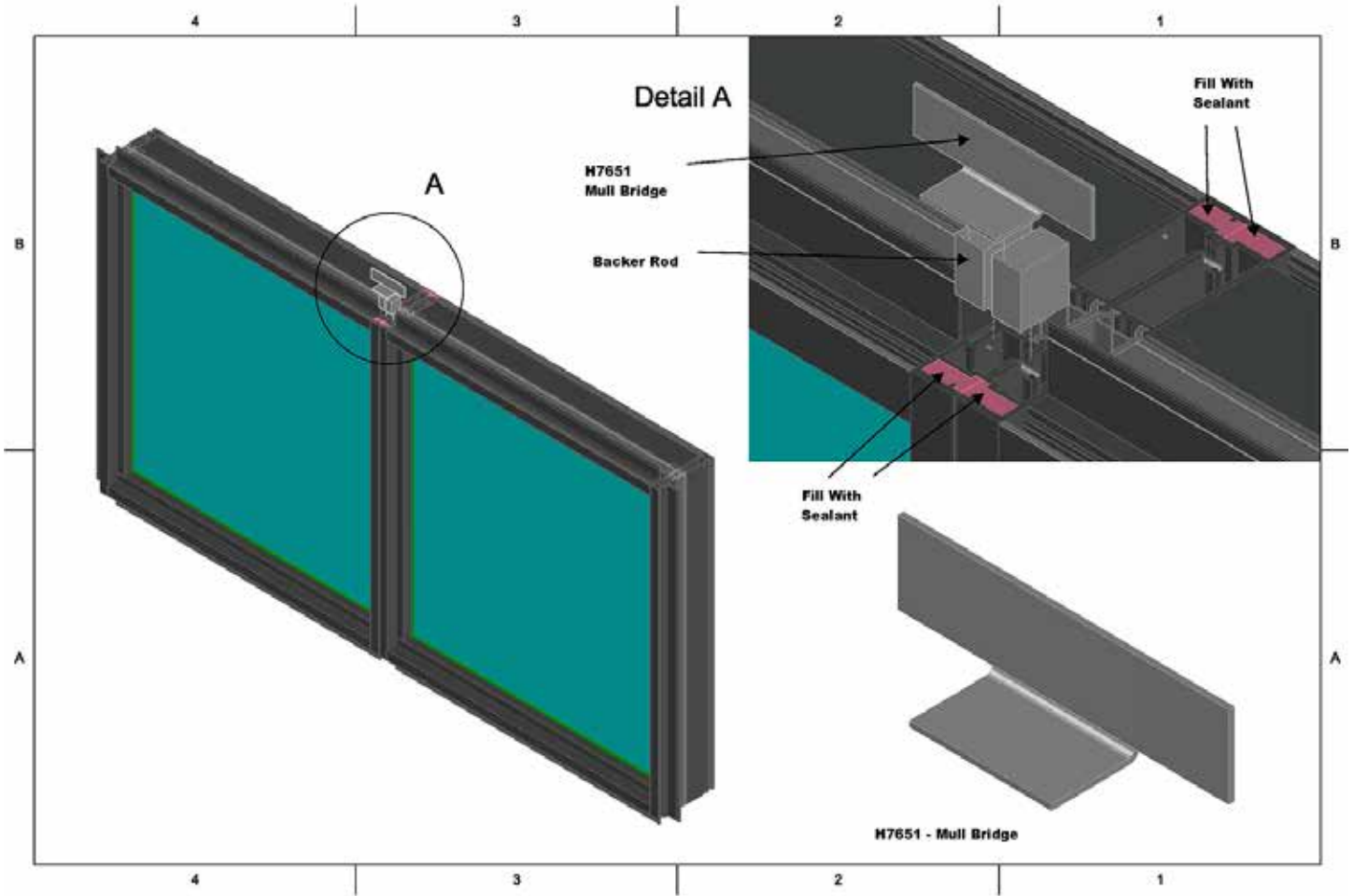



# Nail Fin Application Instructions

Fig. 7

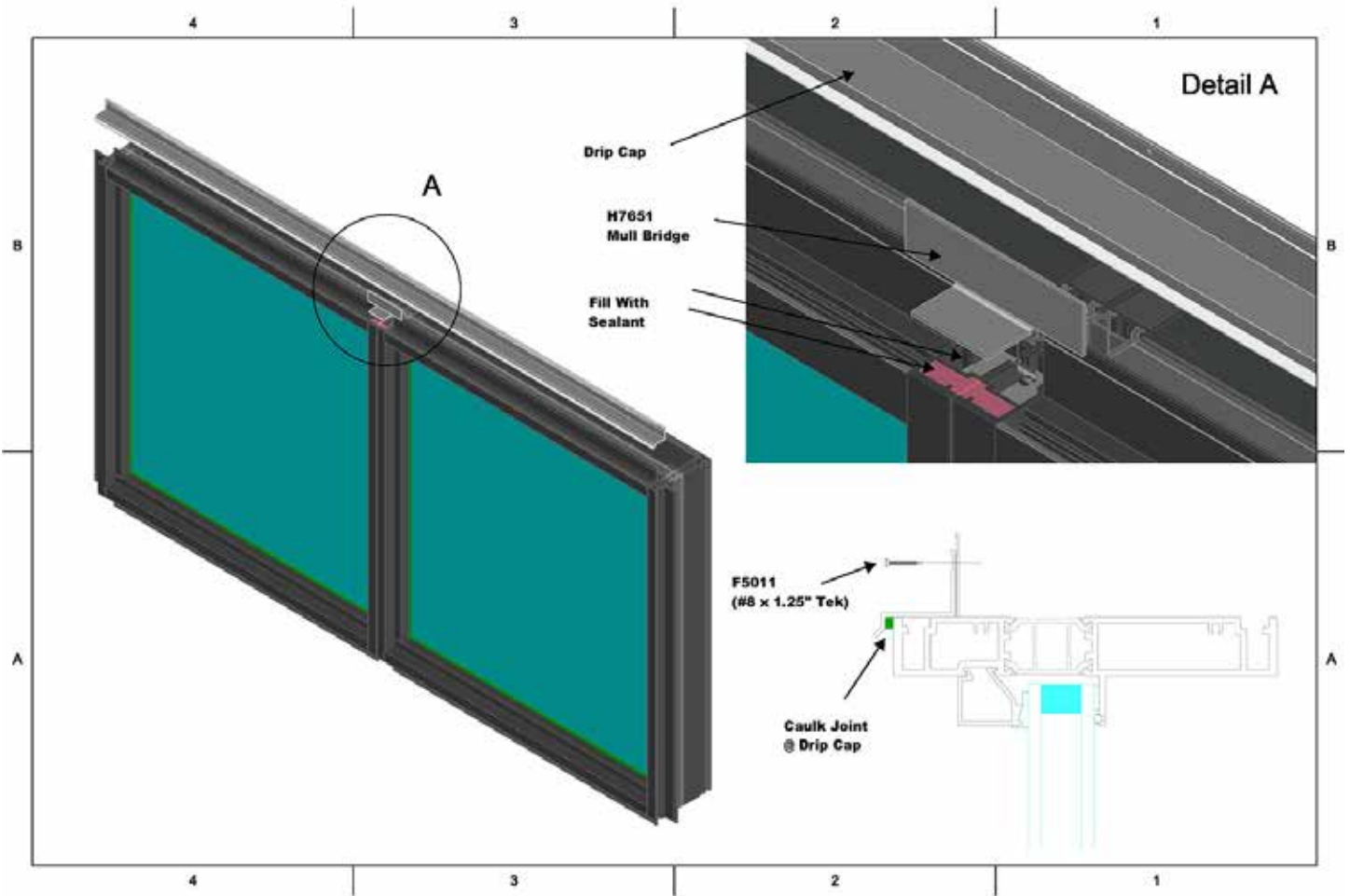



[westernwindowssystem.com](http://westernwindowssystem.com) | 877-268-1300  
2200 E. Riverview Dr., Phoenix, AZ 85034