



Series 3700 Installation Instructions
Multi-Slide Door (Non-Pocketed)

Volume Program

Things to Know Before You Start

Removal of Old Fenestration Products

Ensure any old fenestration products are removed and properly disposed of. You may be able to recycle or donate removed glass and frames. For more information, check with your local recycling agency, the American Architectural Manufacturers Association (AAMA), the US Environmental Protection Agency at www.epa.gov/recycle, or the Building Materials Reuse Association website to locate a nearby company or organization that accepts used windows and doors. To donate removed products, contact local nonprofits in need of building supplies, such as Habitat for Humanity.

Please note: Homes and condominiums built before 1978 may have lead-based paint which can pose serious health hazards during removal. Information and instruction regarding proper management of lead paint is available at www.epa.gov/lead.

Installation Preparation

Multi-slide doors are custom manufactured specific to each application. Prior to installation it is important that you carefully review and understand the installation instructions and any drawings supplied. Western Window Systems' fenestration products should only be installed by experienced and qualified installation professionals. Failure to follow these instructions may result in poor performance including, but not limited to, operation, security, and weatherproofing failures and may void Western Window Systems' express limited warranties.

Product Handling and Storage

This is a finished product that must be protected before, during, and after installation to prevent damage to the glass, frame, finish, and hardware.

Door panels should be stored in a dry location that is protected from the elements. Wet packaging can cause damage to product finishes. If the packaging becomes wet immediately replace it with dry packaging. Door panels should be stored and transported upside down and should not be dropped or dragged from the delivery truck to avoid damage to the bottom rails and rollers systems.

Components

The components supplied will vary depending on the configuration you are installing. Before proceeding with the installation, inspect the components to become familiar with them and confirm that there is no damage that will affect the appearance or performance of the installed product. Damaged or missing parts should be reported to your supplier immediately.

Things to Know Before You Start

Other Tools and Products Necessary for Installation

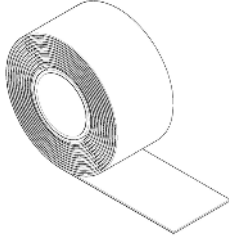
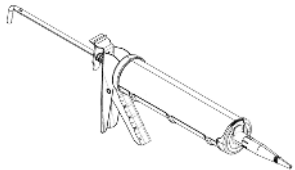
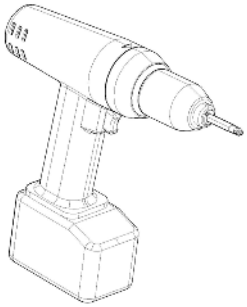
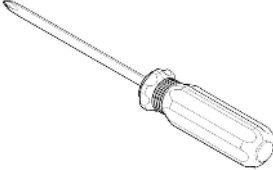
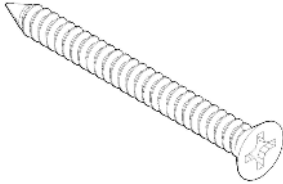
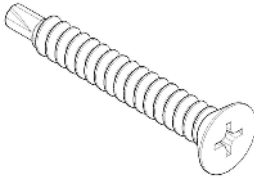
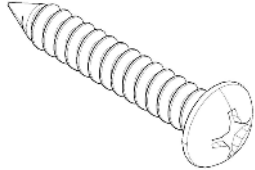
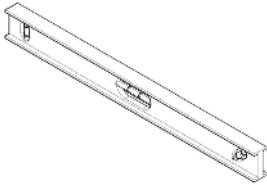
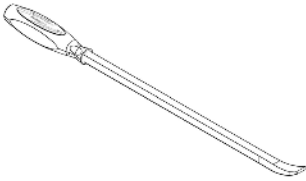
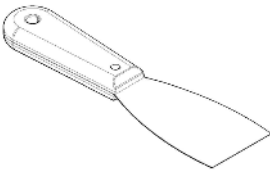
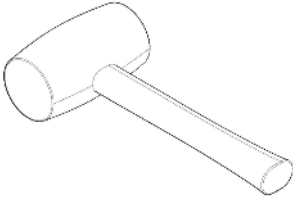
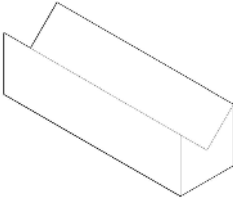
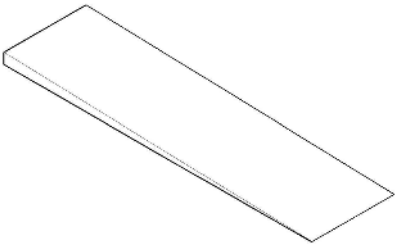
<p>Flashing membrane</p> 	<p>Sealant that is compatible with flashing membrane</p> 	<ul style="list-style-type: none"> - Impact driver with #2 Phillips bit - Drill with 6" long 5/64" drill bit - Hammer drill with 1/4" bit (only required for masonry installation) 	
<p>#3 Phillips screwdriver</p> 	<p>#10 x 2" PPH screws for frame installation</p> 	<p>#8 x 1" PPH screws</p> 	<p>1 1/4" pan head self-taping screws for nail-fin fastening</p> 
<p>Levels of various size or laser level</p> 	<p>Pry bar</p> 	<p>Putty knife</p> 	<p>Dead blow rubber mallet</p> 
<p>Plastic block</p> 	<p>Shims. Except in circumstances where a particular shim type is specified by applicable building codes, either wedge shims or horseshoe shims may be used. Shimming must be even across the door unit. Each shim must be long enough to cover the full width of the door frame from front to back.</p> 		

Components

Rough opening must be waterproofed in accordance with AAMA Installation Masters standards, flashing and sealant manufacturer instructions, and meet all local building codes. Please refer to videos provided on line at: <https://www.westernvolumeprogram.com/professionals/dealer/>

Frame Components

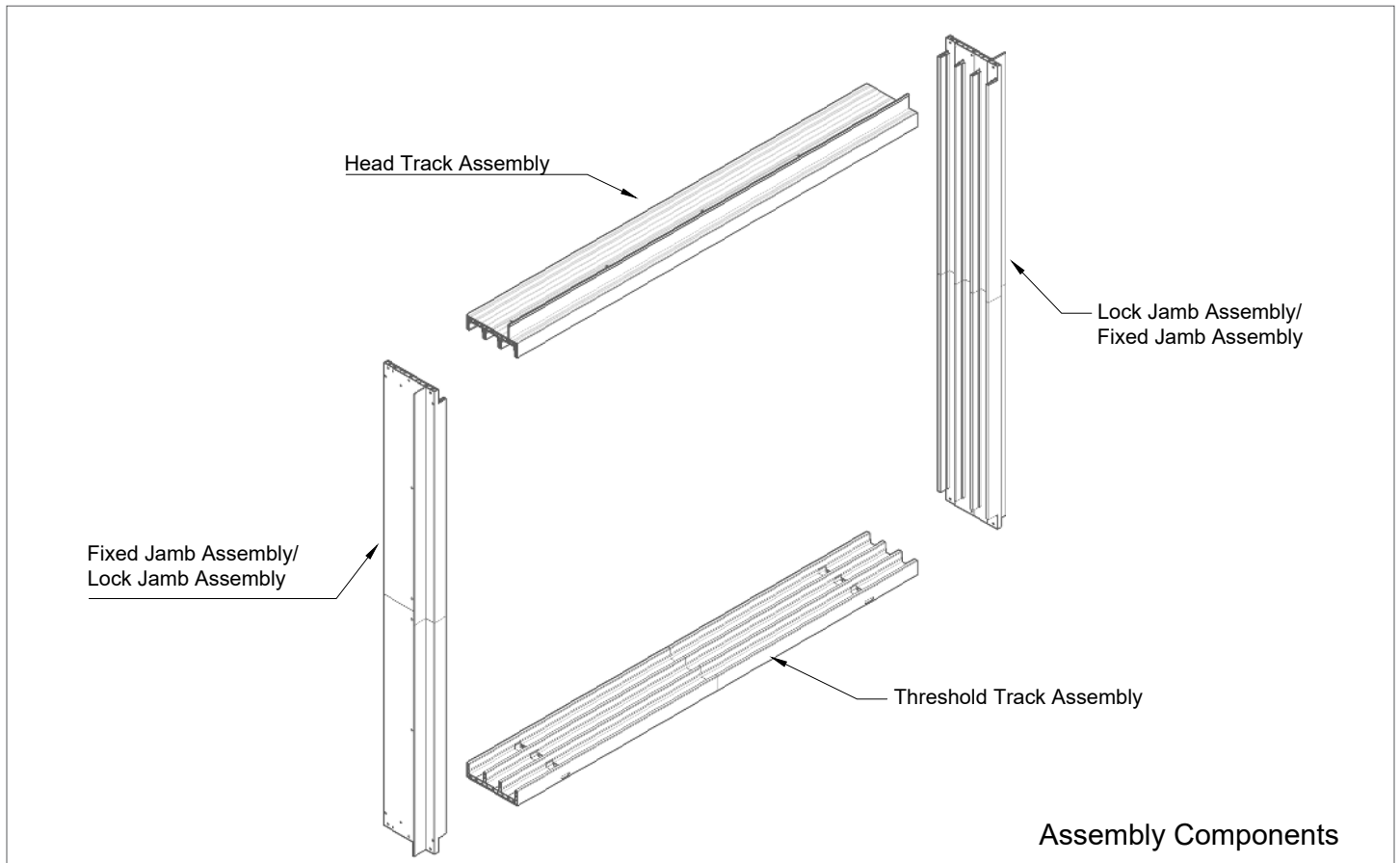

Each door will have a head track assembly, threshold track assembly, lock jamb assembly, and fixed jamb assembly.

Step 1 - Frame Installation

Fig. 1.1

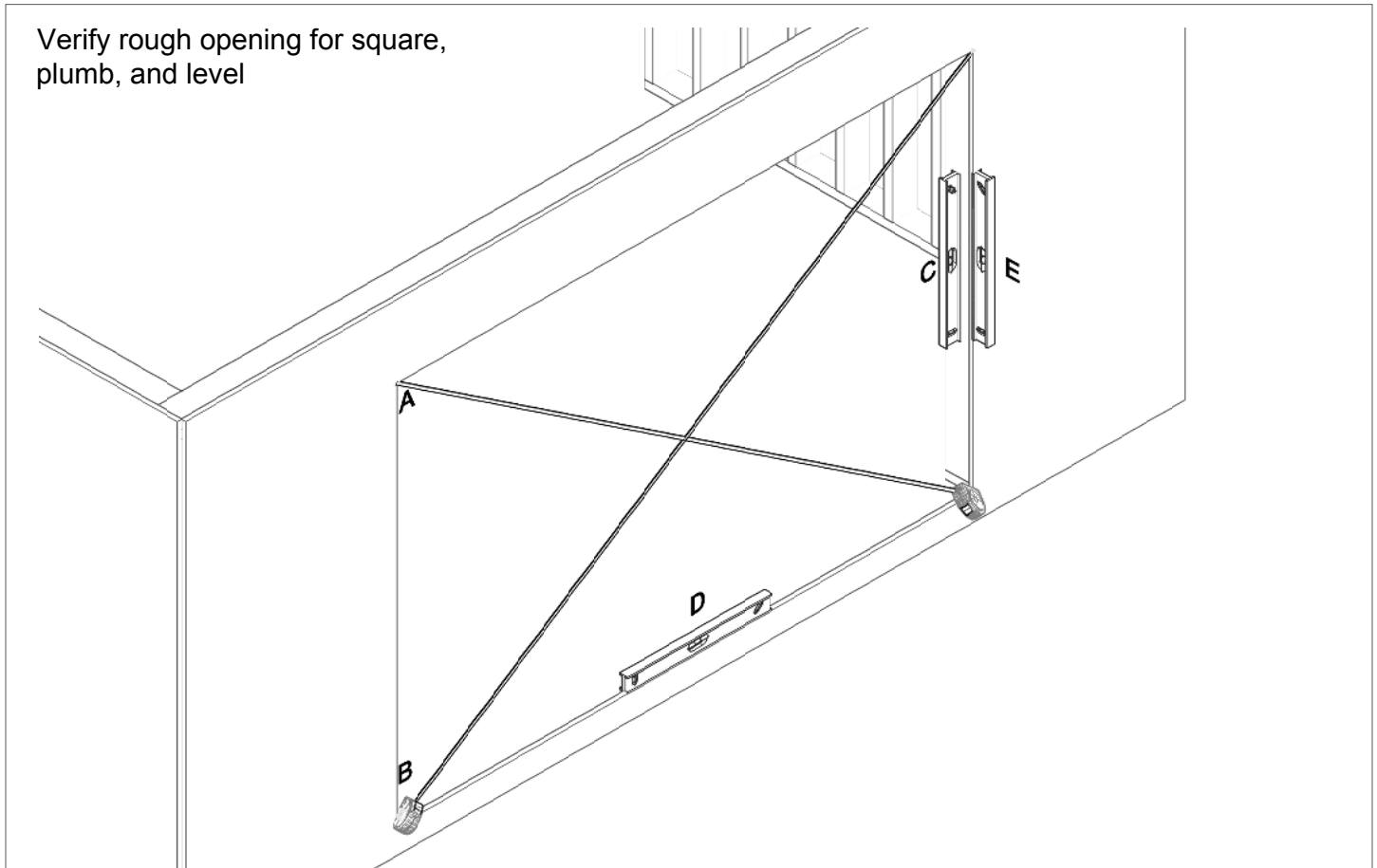

- a. Inspect the rough opening carefully to ensure it has been prepared correctly to accept the configuration and size you are installing. See Fig. 1.1.
- b. Check the floor to see that it is flat and level. If the floor varies more than $.0625''$ ($1/16''$) per foot or a total of $.25''$ ($1/4''$) over the entire width of the opening, it must be corrected before proceeding with installation.

Step 2 - Frame Installation

Fig. 2.1

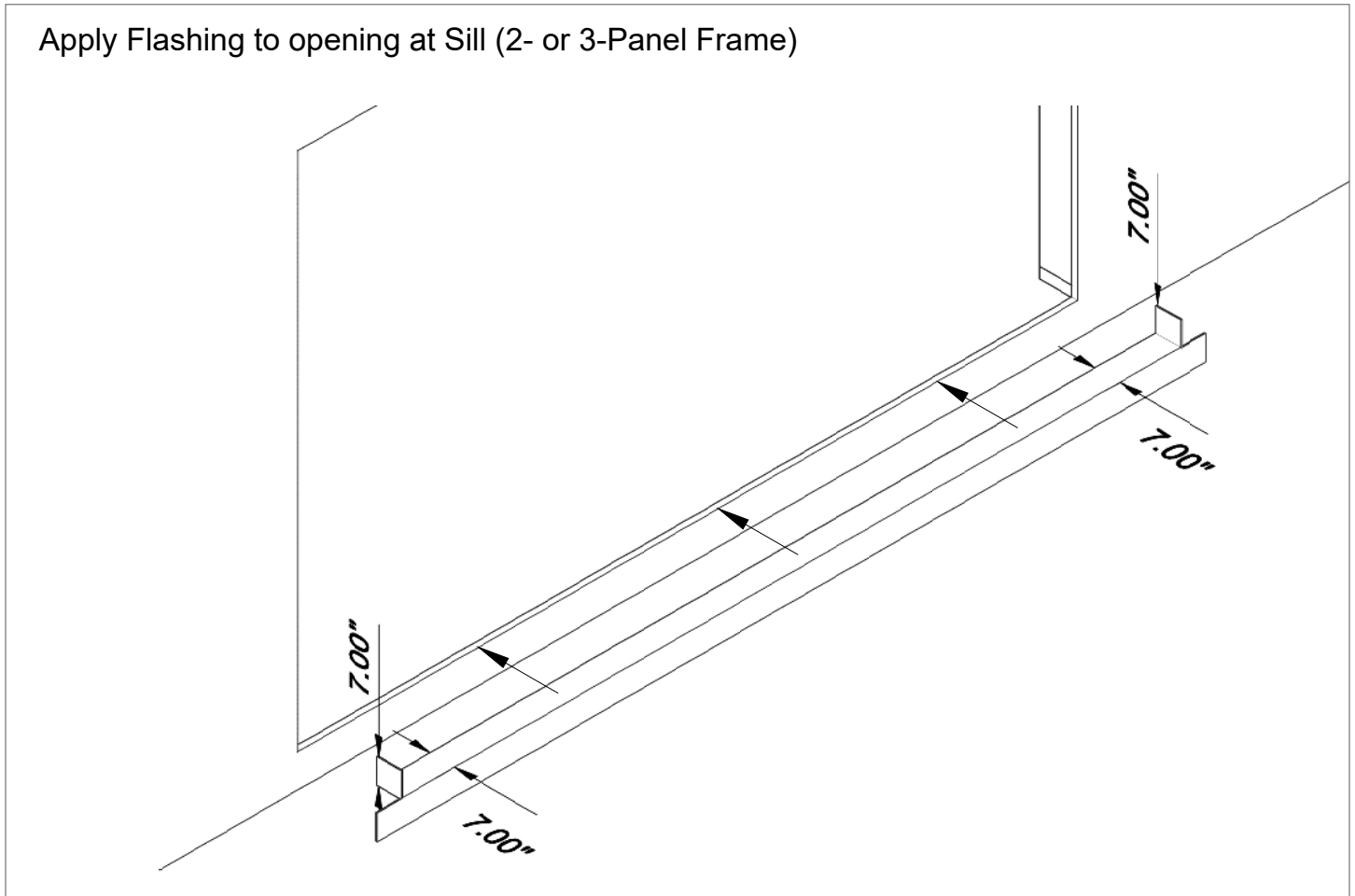

- a. Flash sill followed by the jambs. See Figs. 2.1 and 2.2 for 2- and 3-panel doors. See Figs. 2.3 and 2.4 for 4-panel doors.

Step 2 - Frame Installation

Fig. 2.2

Apply Flashing to opening at Jambs (2- or 3-Panel Frame)

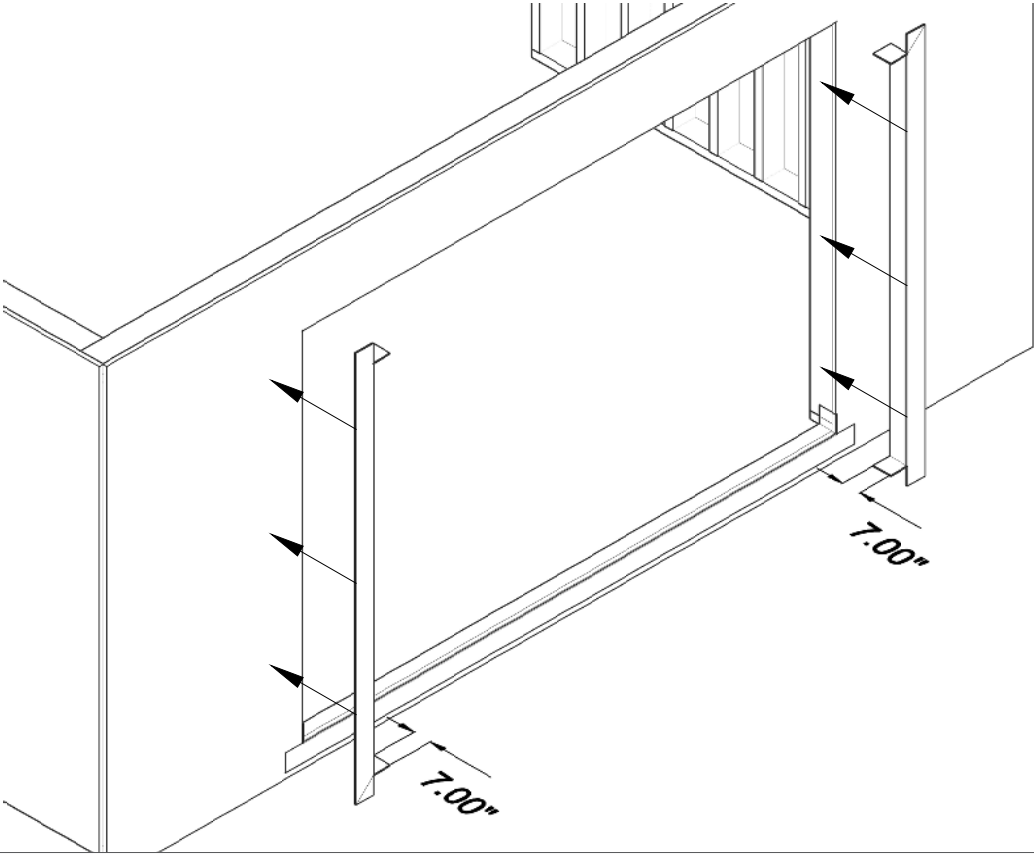

Step 2 - Frame Installation

Fig. 2.3

Apply Flashing to opening at Jambs (4-Panel Frame)

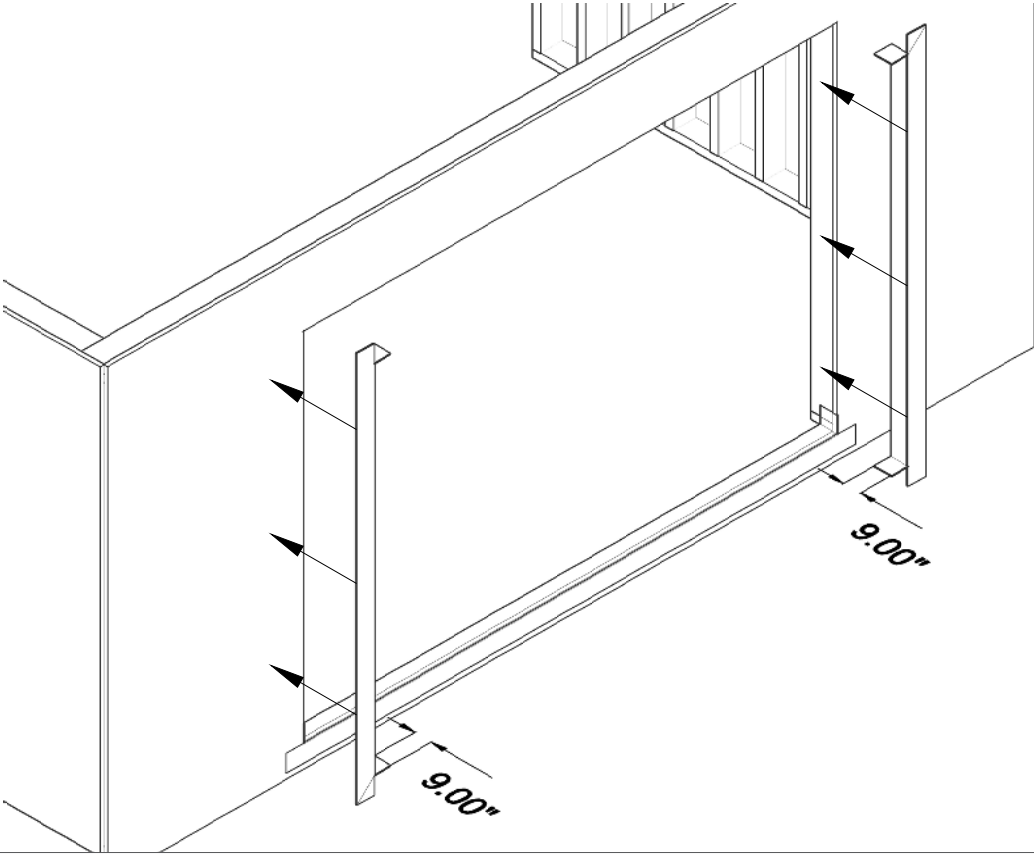

Step 3 - Frame Installation

Fig. 3.1

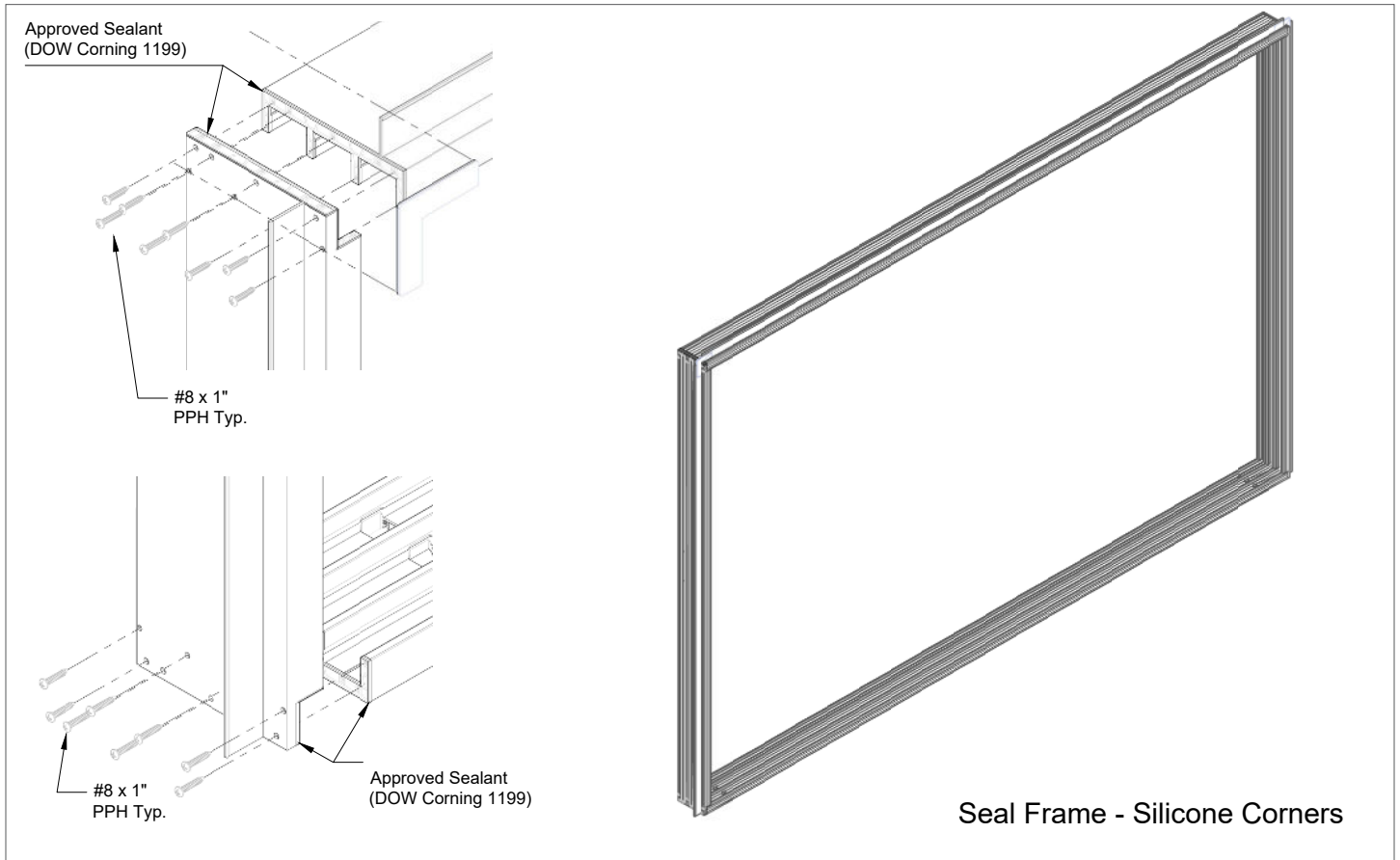

- a. Seal corner joints and assemble frame using supplied #8 X 1" PPH screws. See Fig. 3.1.

Step 3 - Frame Installation

Fig. 3.2

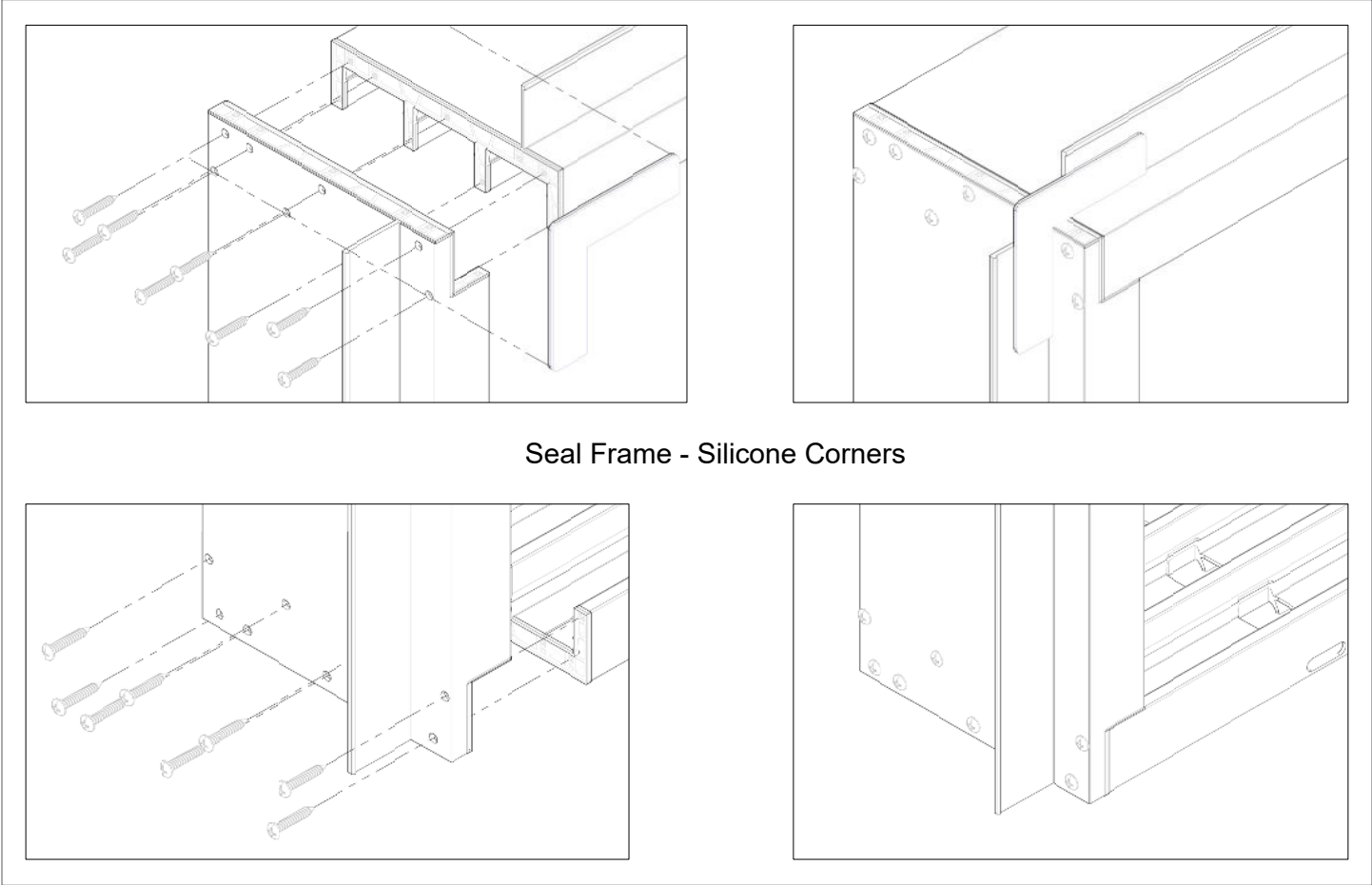

Seal Frame - Silicone Corners

b. Seal corner joints and assemble frame using supplied #8 X 1" PPH screws. See Fig. 3.2.

Step 4 - Frame Installation

Fig. 4.1

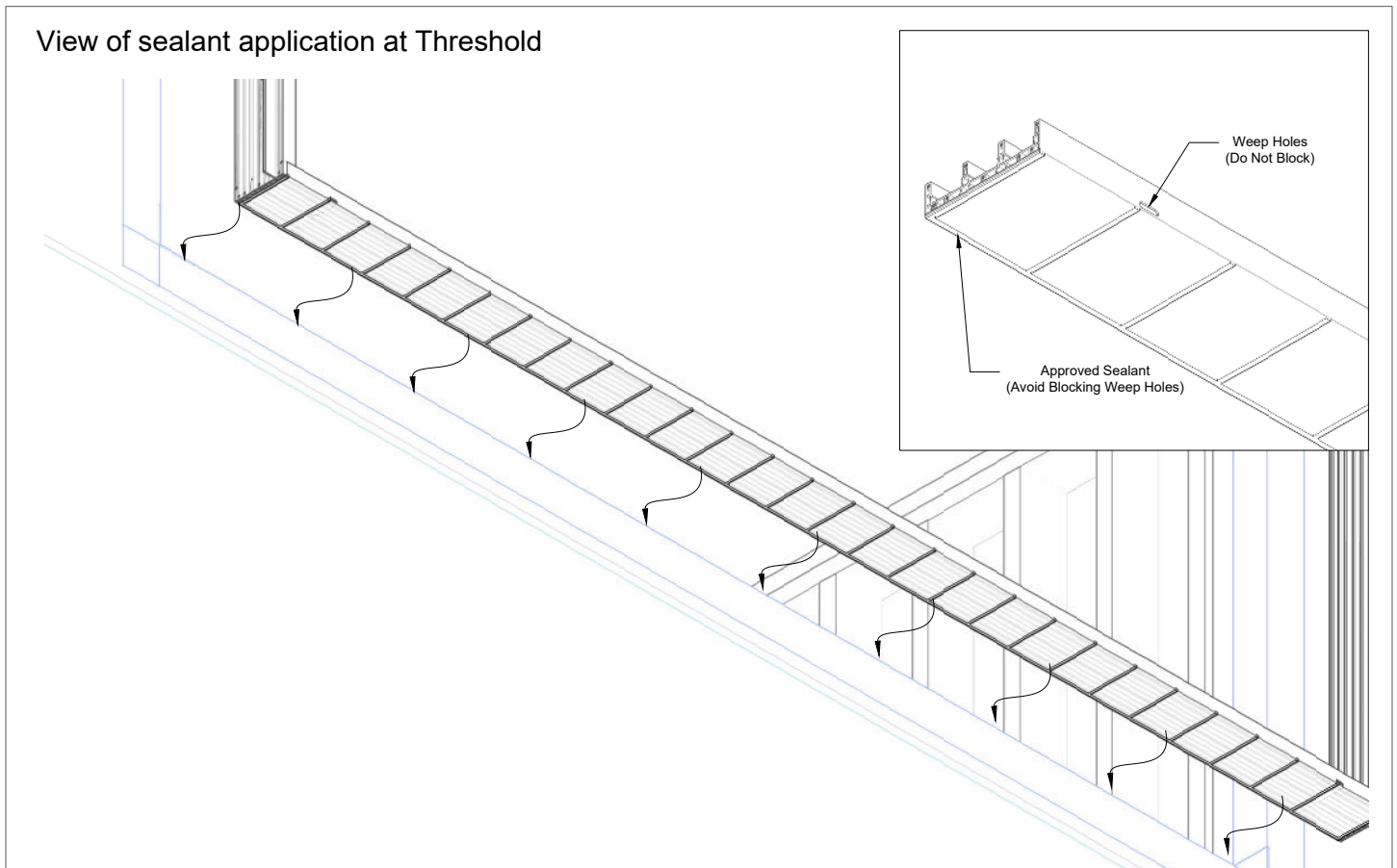

- a. Apply a .50" (1/2") wide by .50" (1/2") high bead of sealant on the floor from jamb to jamb applying 6" up the jamb and from the inside corners across the end to the outside edge of where the threshold will be. Inspect the sealant carefully to ensure that a complete water barrier has been accomplished across the full width of the opening. Add lines of sealant from the inside bead straight out as shown in Figs. 4.1, 4.2, and 4.3.

Step 4 - Frame Installation

Fig. 4.2

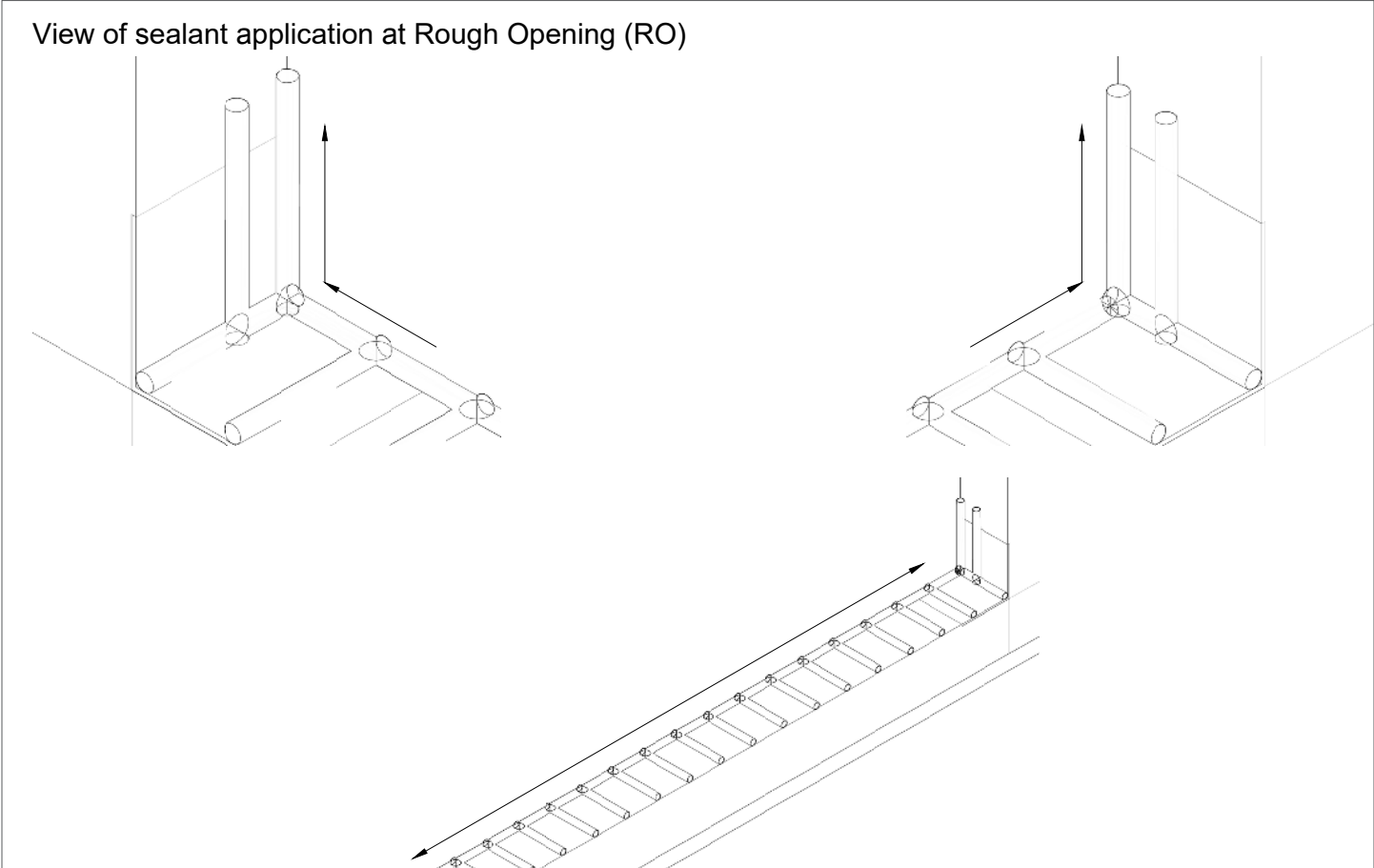

Step 4 - Frame Installation

Fig. 4.3

View of sealant application at perimeter of Rough Opening (RO)

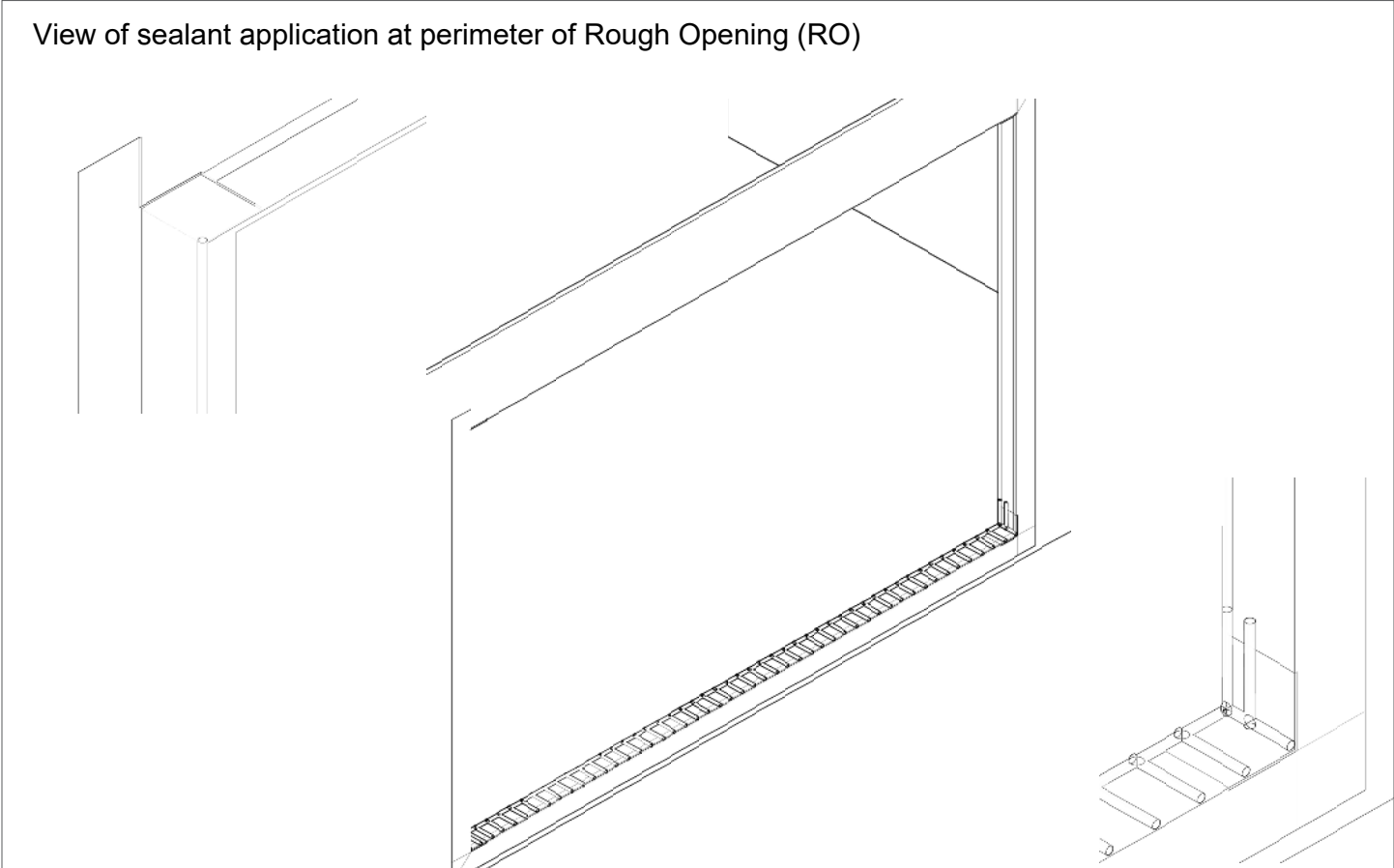

Step 5 - Frame Installation

Fig. 5.1

Install assembled Frame

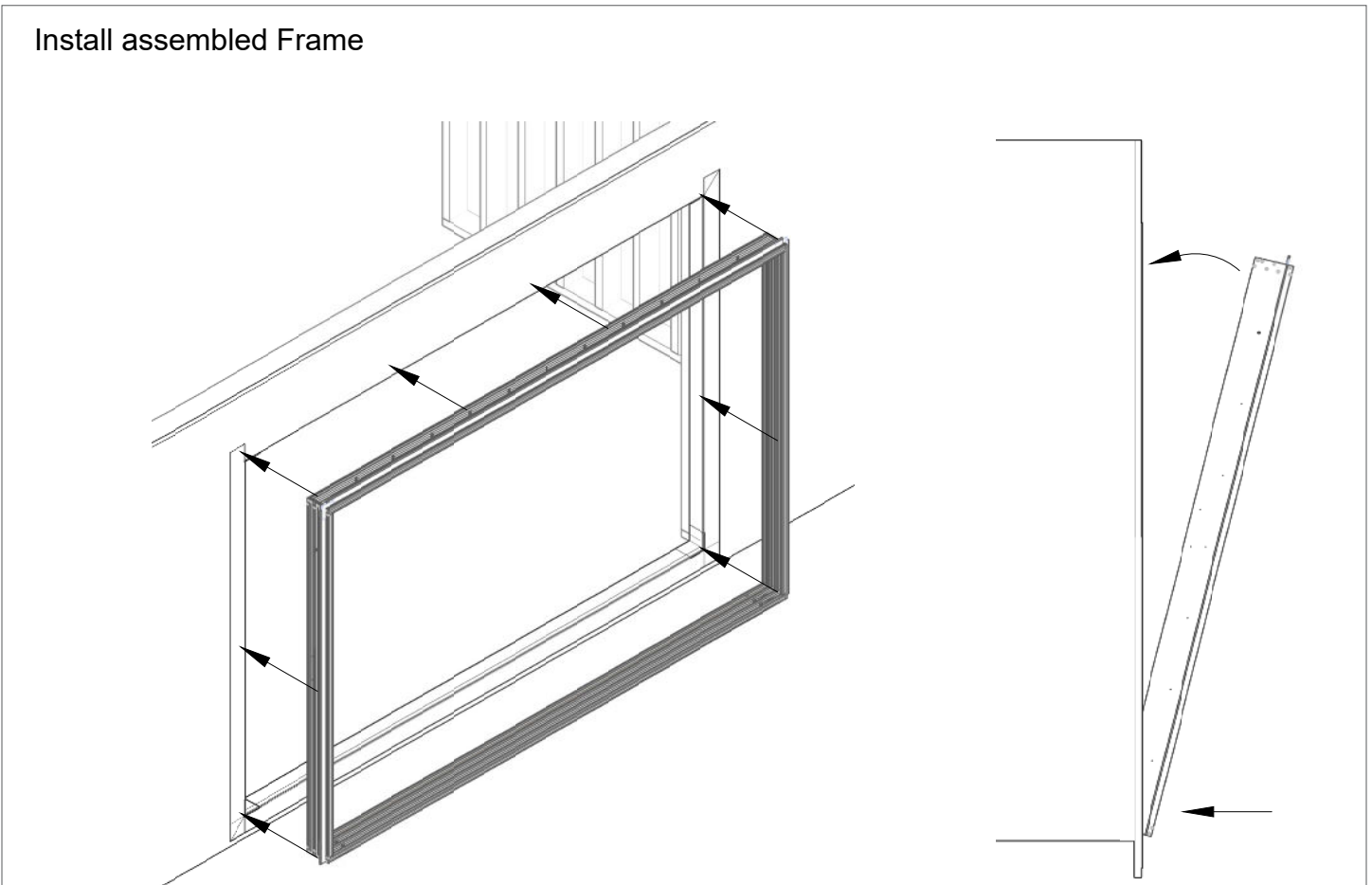

- a. Tilt the door frame into the rough opening setting the sill first. See Fig. 5.1.
- b. Shim sill as needed to level. Shims should be no more than 6" apart.

Step 5 - Frame Installation

Fig. 5.2

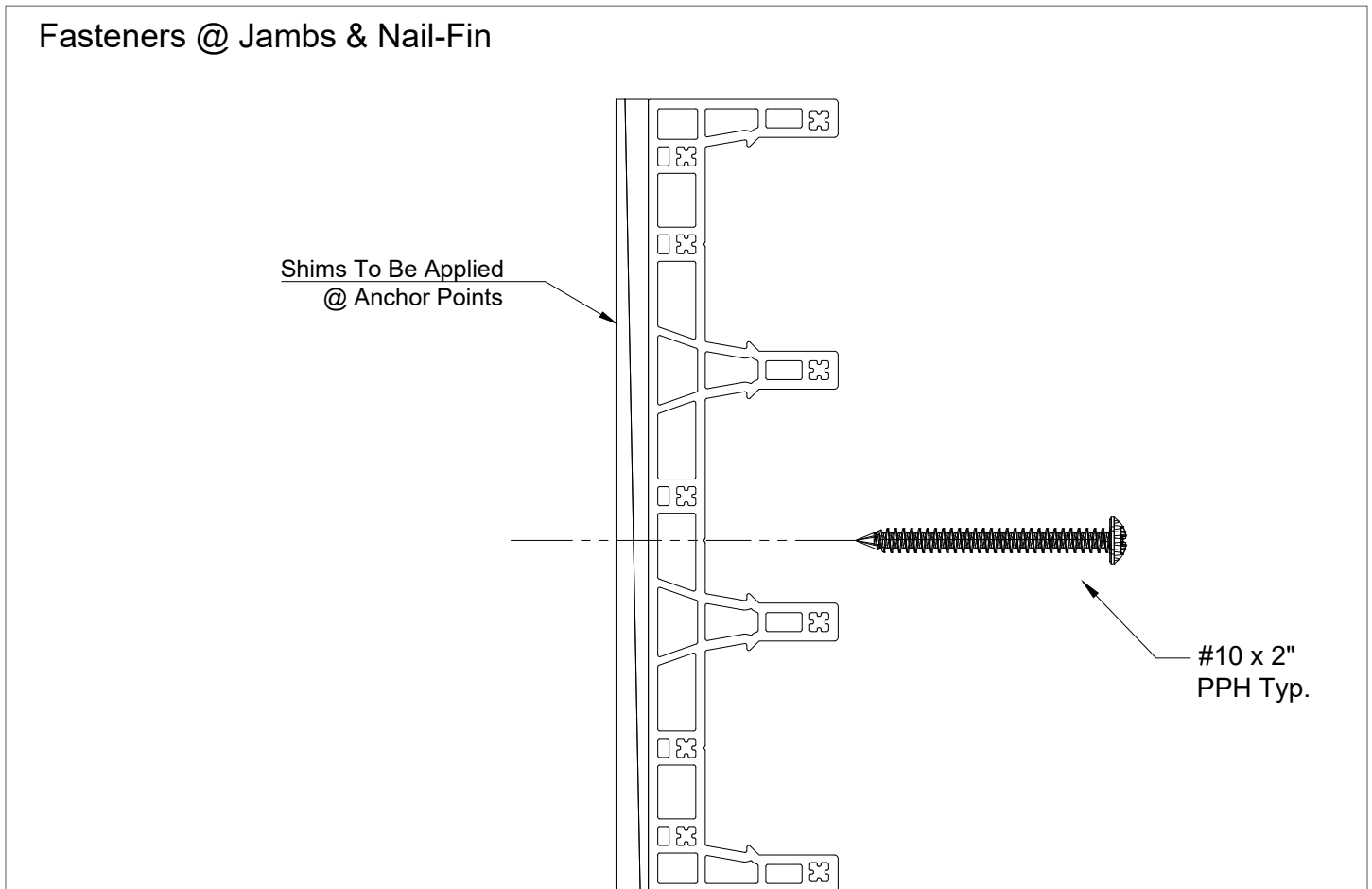

- c. Plumb and anchor jambs using #10 X 2" PPH screws located 6" from each corner and 12" on center. Shim at all anchor points. See Figs. 5.2 and 5.3.

NOTE: When anchoring through the jambs, be certain to offset the screw location so that it lines up with the indentation line in the jamb. This will eliminate any interference with the middle leg of the jamb cover when applying it later in the process.

Step 5 - Frame Installation

Fig. 5.3

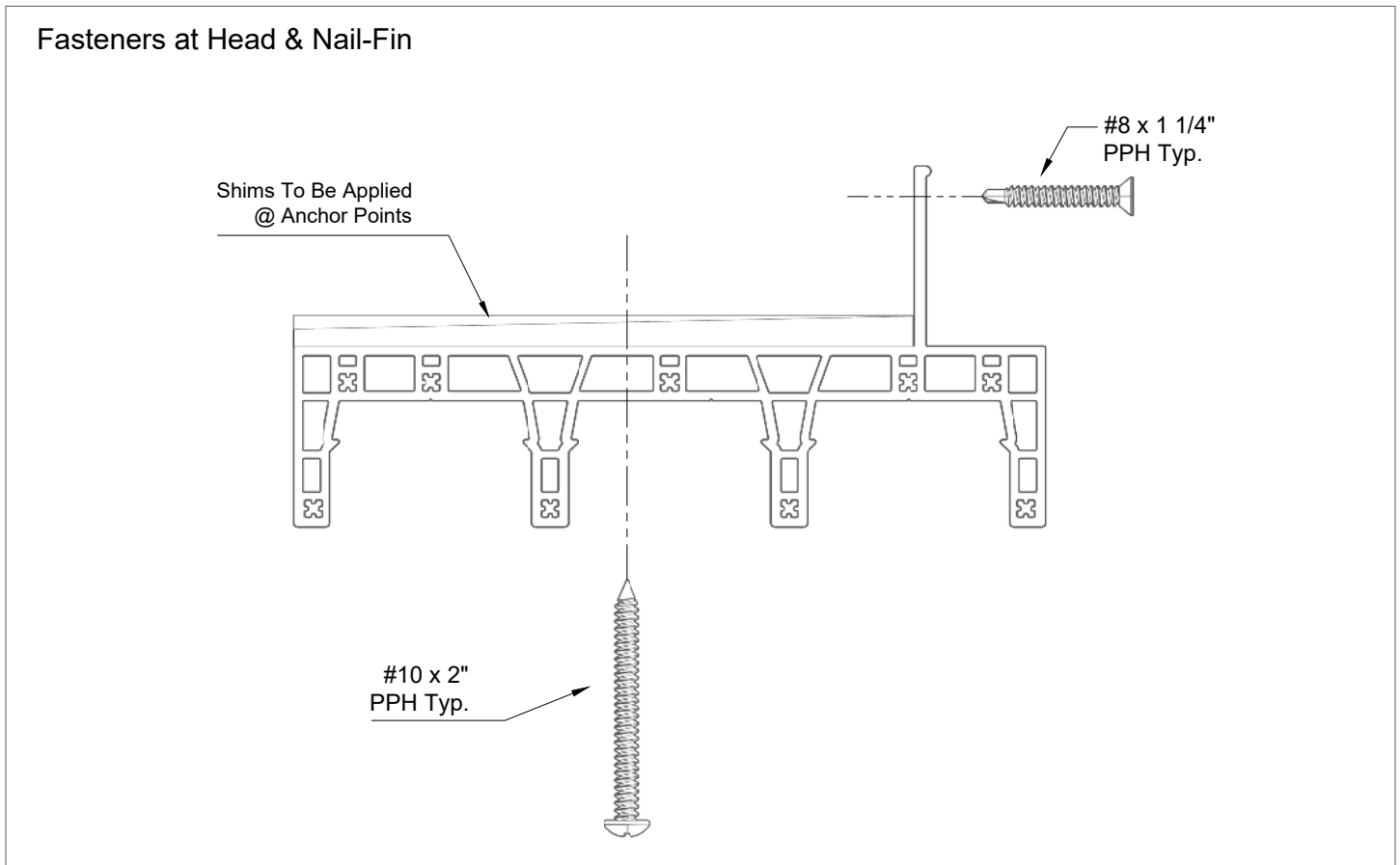

- d. Plumb and anchor head using #10 X 2" PPH screws located 6" from each corner and 12" on center. Shim at all anchor points. See Figs. 5.3 and 5.4.

Step 5 - Frame Installation

Fig. 5.4

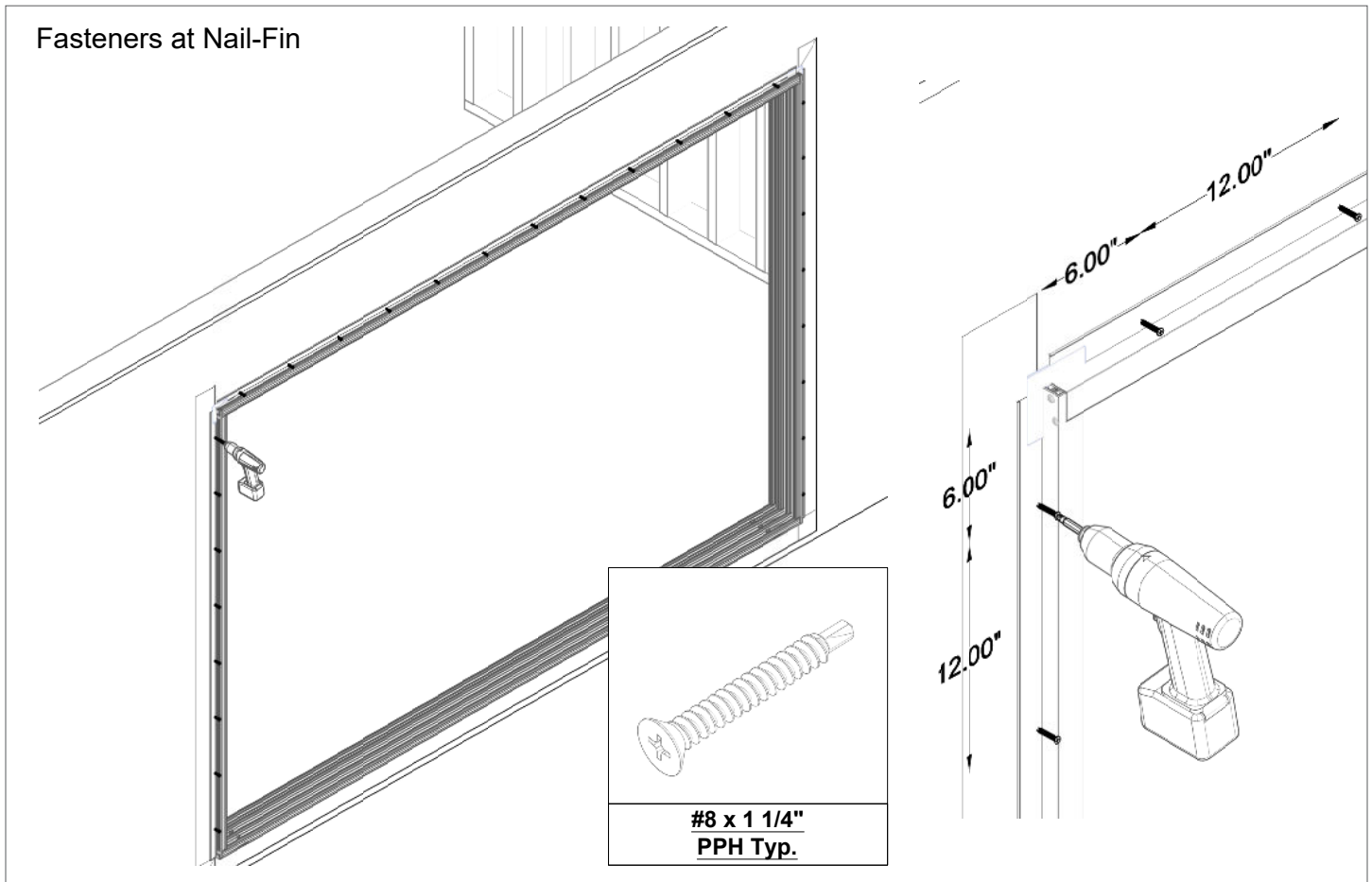

- e. Once anchoring is finished, walk on the track full length to settle sealant.
- f. Cross tape frame corner to corner to ensure it is square.
- g. Apply self adhesive corners to the main frame to cover the gap. Apply sealant around the edges and tool sealant flat.

Step 5 - Frame Installation

Fig. 5.5

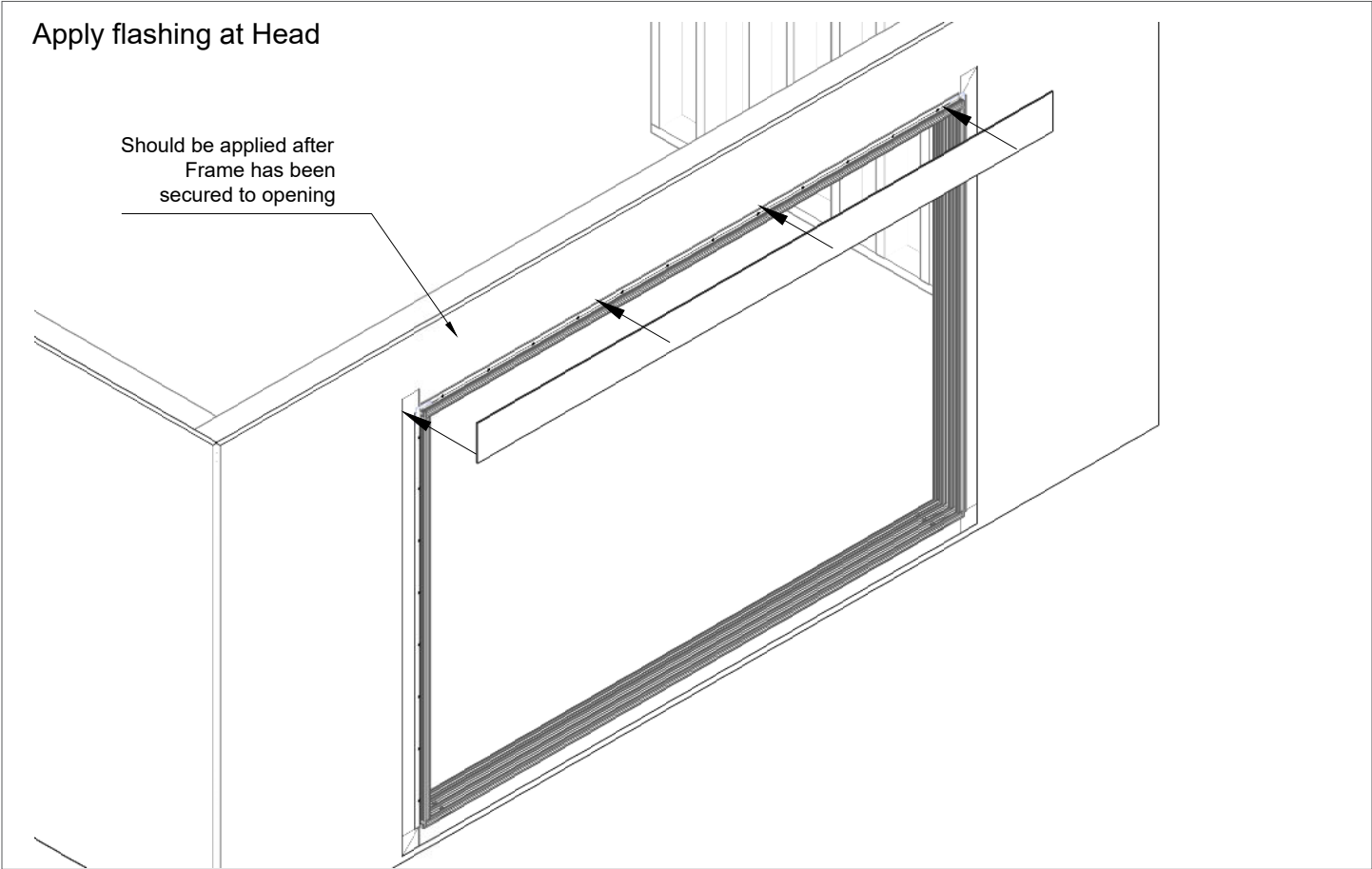

h. Apply head waterproofing. See Fig. 5.5.

Step 6 - Lead Panel Installation

Panel Instruction

Remove the black foam blocks from the head channels. The blocks are approximately 1" x 1" x 2.25", and there will be one in each channel except the locking panel channel. Set them aside temporarily; they will be reinstalled when the panel installation is complete.

Each panel will be marked with a white label which includes the unit number and a panel designation. Lead Panel, Intermediate Panel, and Fixed Panel will be labeled accordingly.

Identify the Lead Panel.

Fig. 6.1

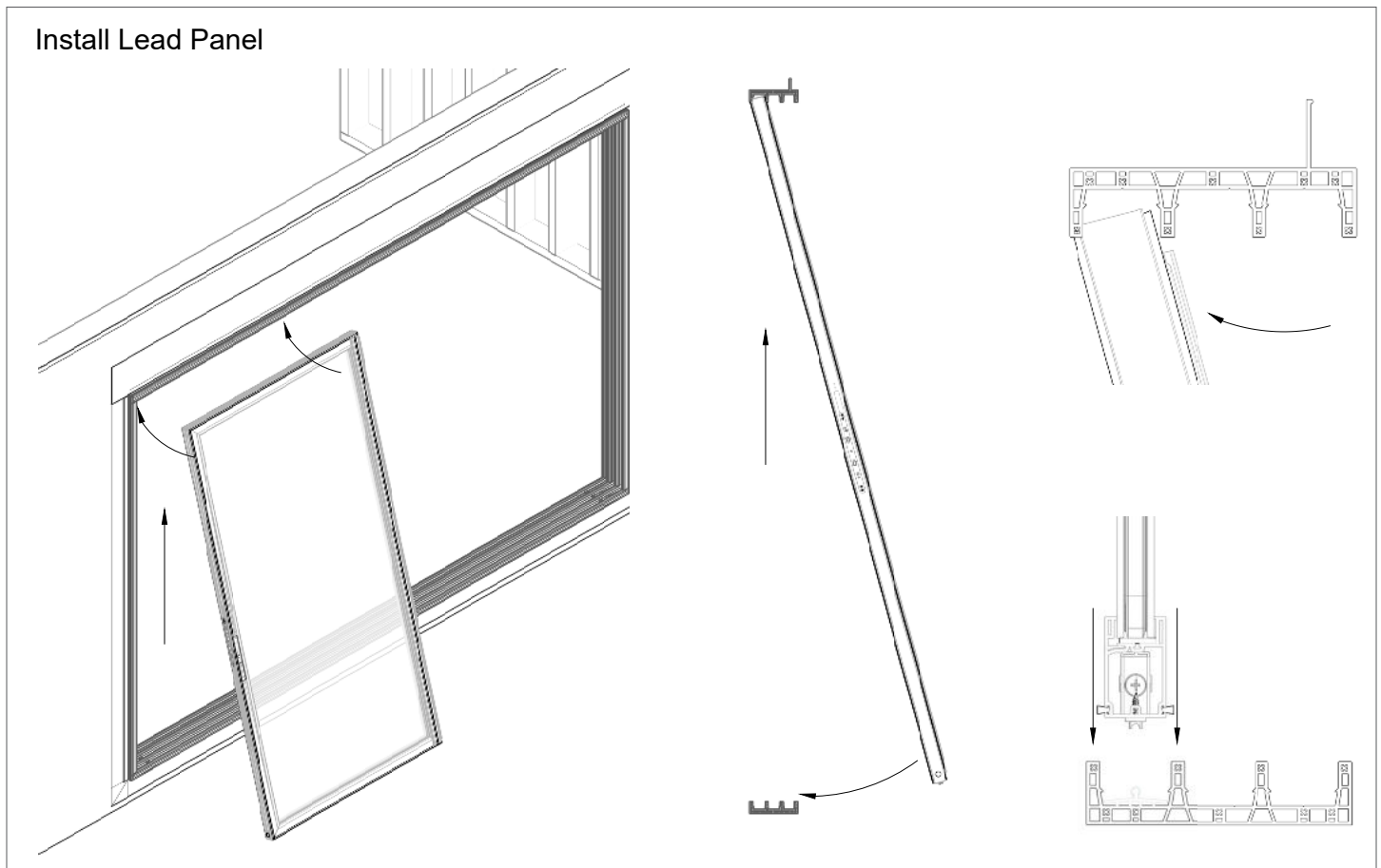

- a. From the outside of the building, with the glazing stop to the inside, lean the top of the panel in and insert it into the extreme interior head track and lower it onto the threshold. See Fig. 6.1.

Step 6 - Lead Panel Installation

Fig. 6.2

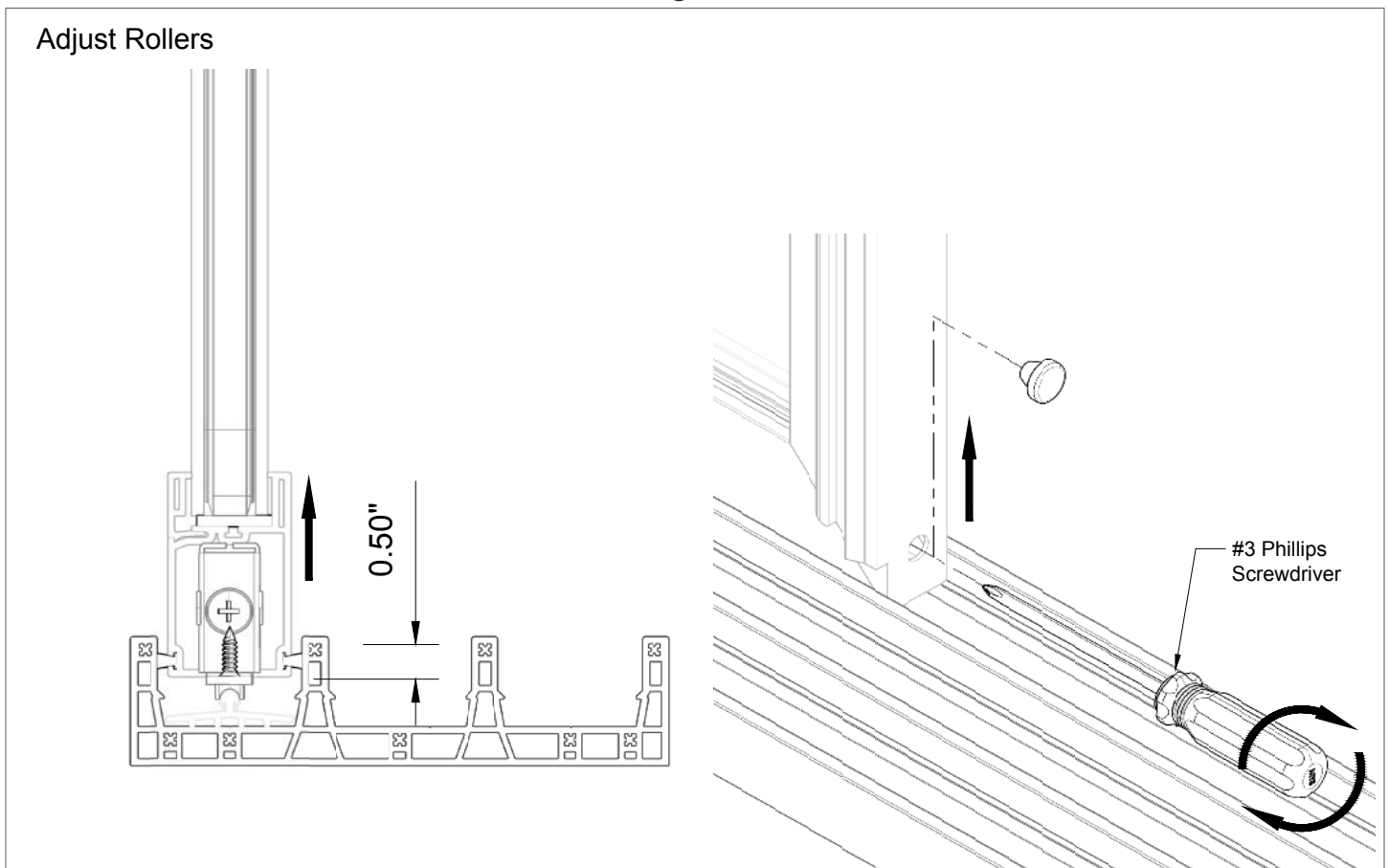

- b. Using a #3 Phillips screwdriver, insert through the hole at the bottom of each stile and adjust the rollers up $\frac{1}{2}$ ". Roll the panel towards the lock jamb to view the vertical gap between the panel and lock jamb. Make final roller adjustments so the gap is consistent from top to bottom of the panel. See Fig. 6.2.

Step 6 - Lead Panel Installation

Fig. 6.3

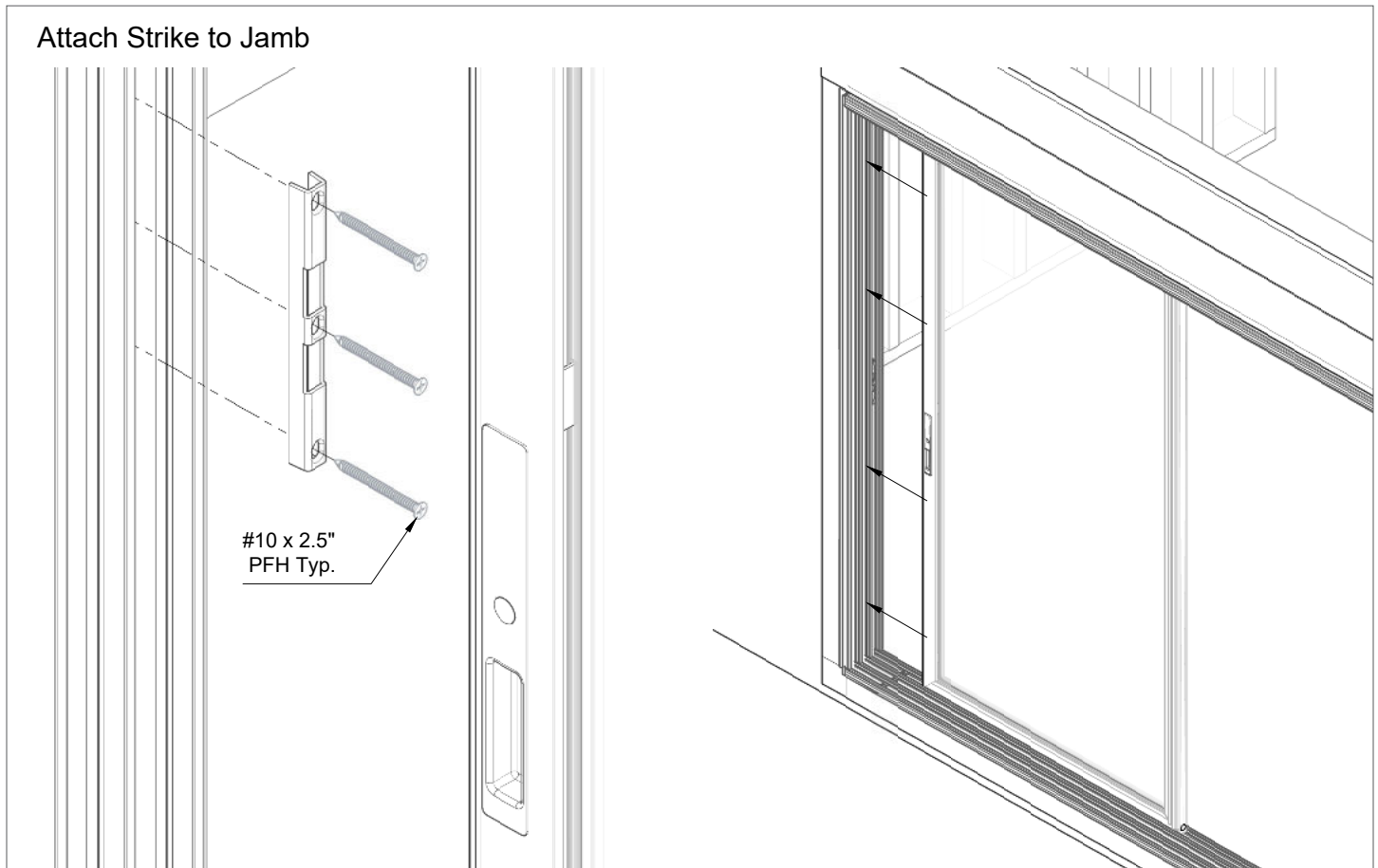

- c. Attach the strike to the jamb. Confirm proper locking action. See Fig. 6.3.

Step 6 - Lead Panel Installation

Fig. 6.4

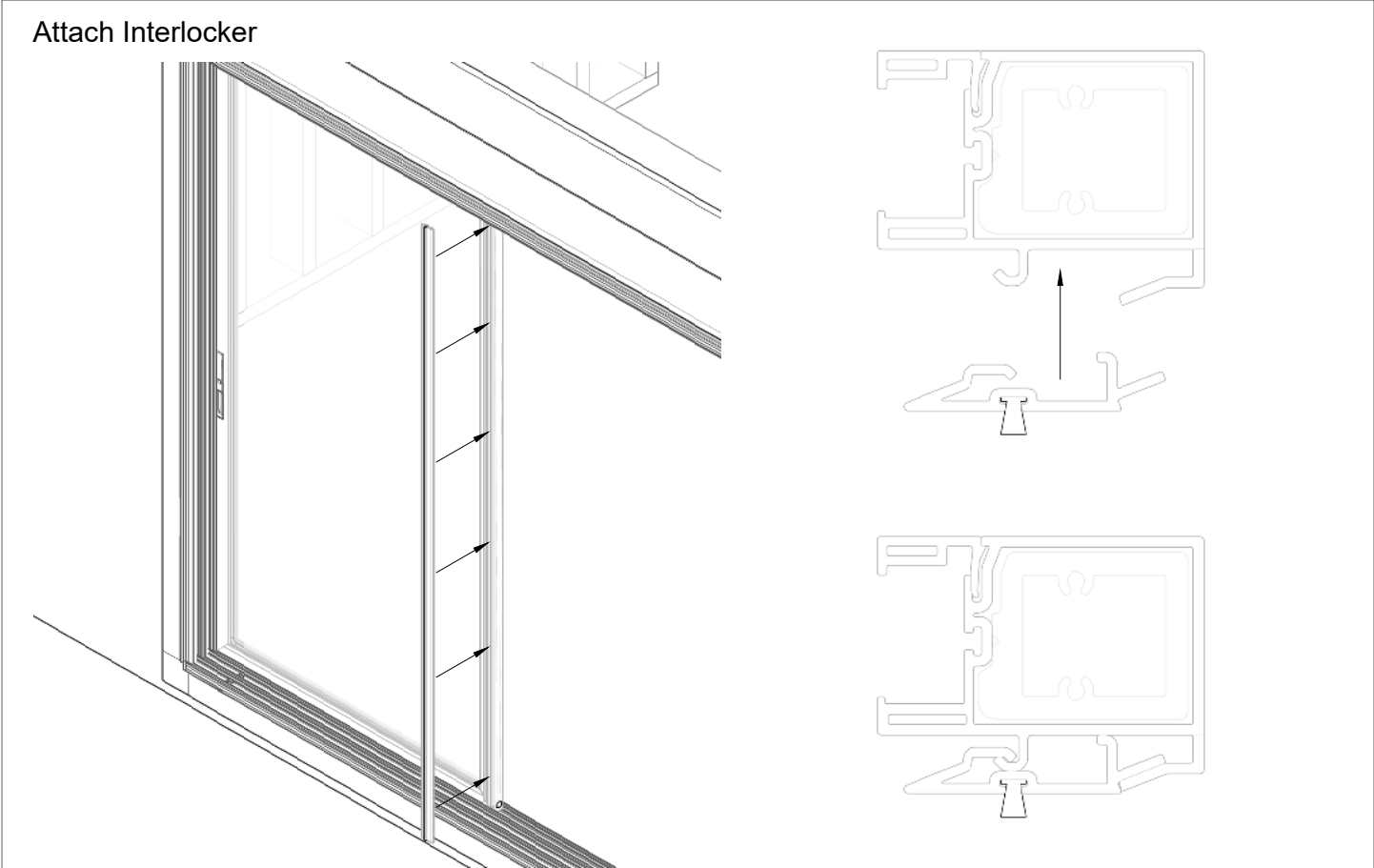

d. Attach the interlocker. See Fig. 6.4.

Step 6 - Lead Panel Installation

Fig. 6.5

Slide Panel full width to confirm smooth operation

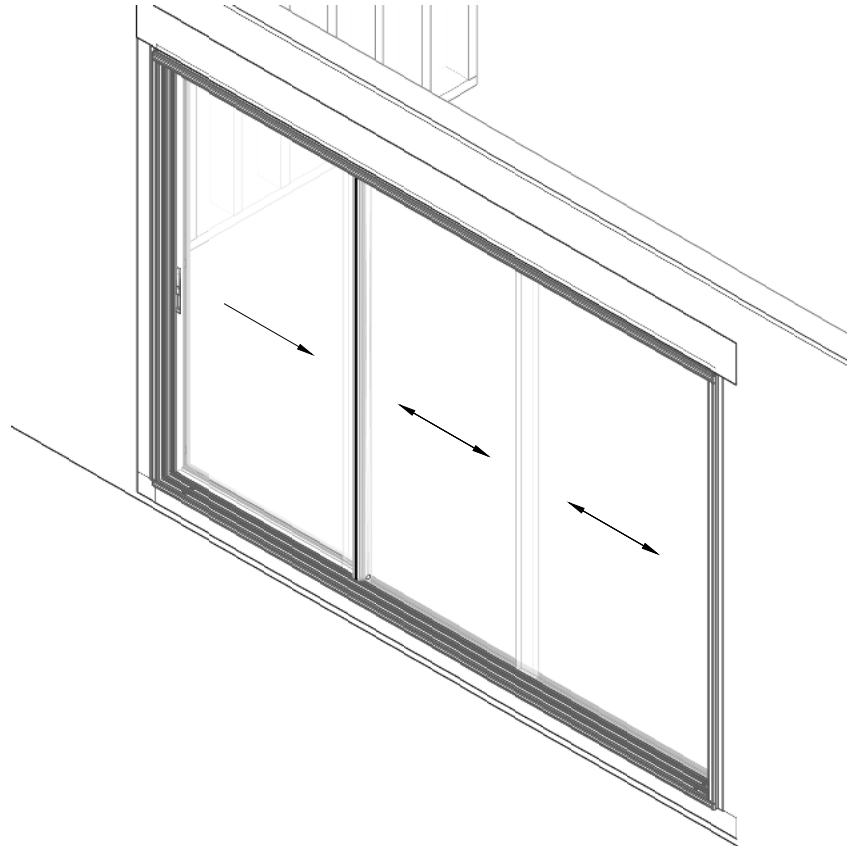

- e. Slide panel full width to confirm smooth operation. See Fig. 6.5.

Step 7 - Intermediate Panel Installation

Fig. 7.1

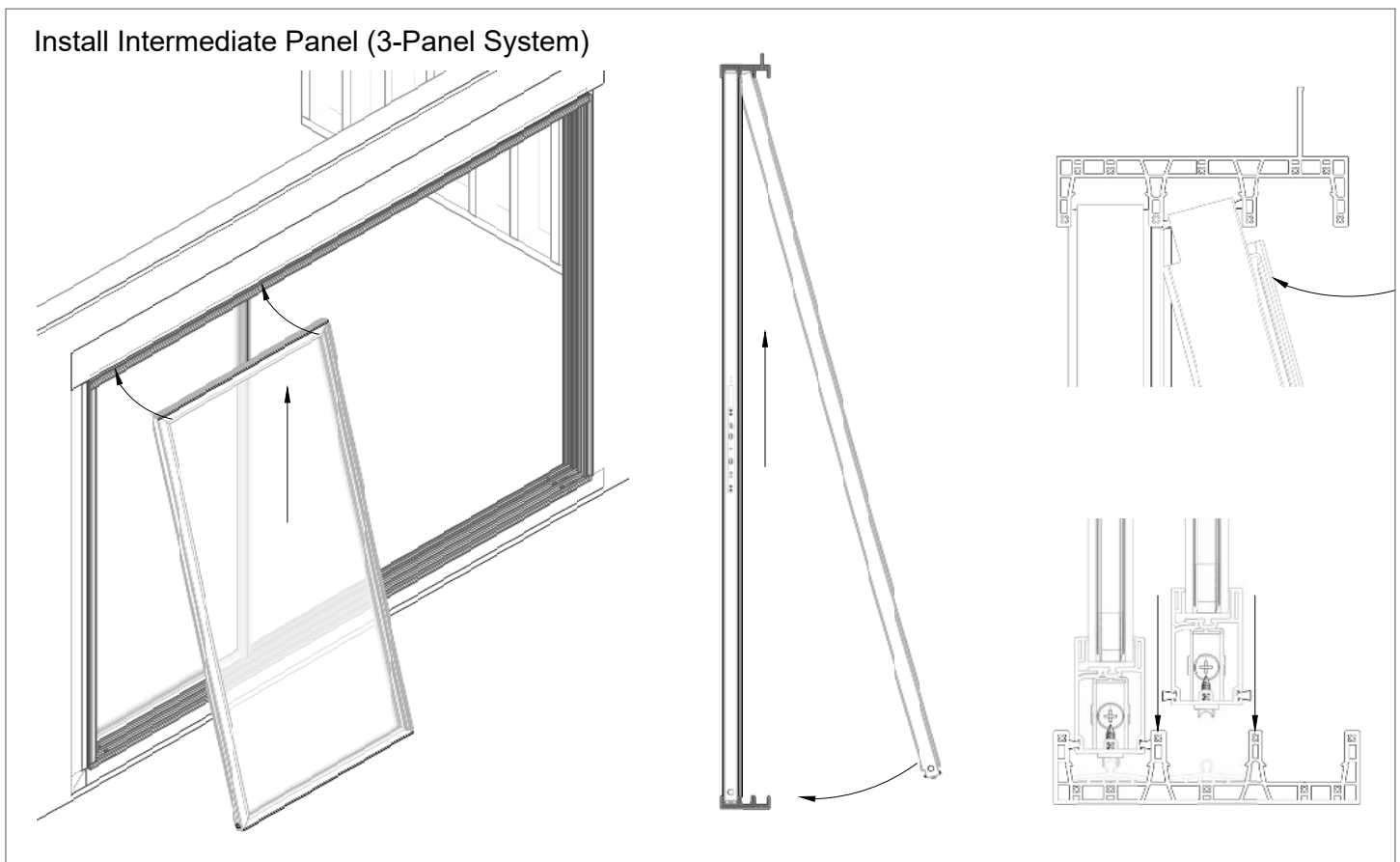

- a. Locate the intermediate panel that is to be installed directly adjacent to the lead panel.
- b. From the outside of the building, with the glazing stop to the inside and interlocker overlapping the lead panel, lean the top of the panel in and insert it into the center head track and lower it onto the threshold. See Fig. 7.1.

Step 7 - Intermediate Panel Installation

Fig. 7.2

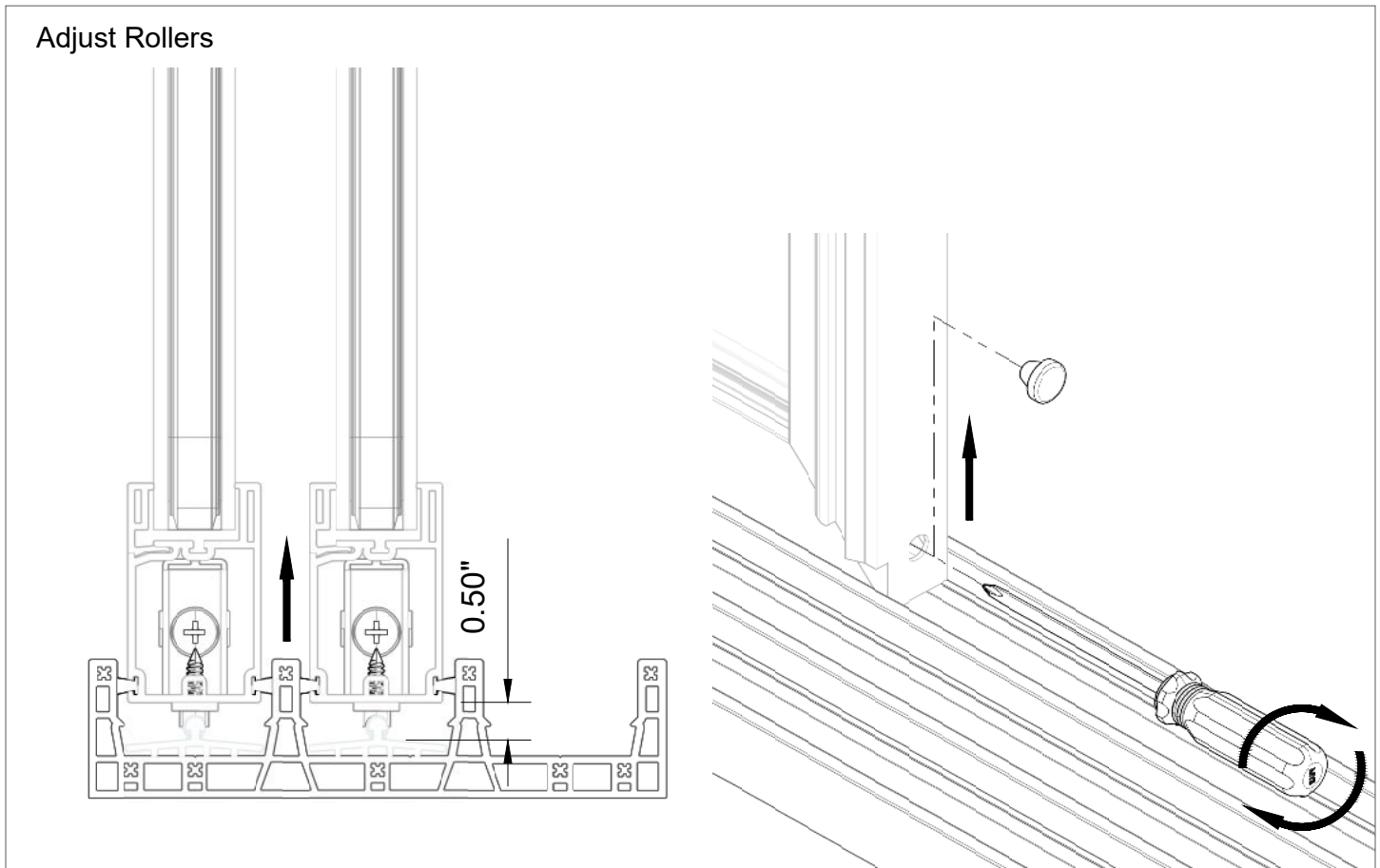

- c. Using a #3 Phillips screwdriver, insert through the hole at the bottom of each stile and adjust the rollers up $\frac{1}{2}$ ". Roll the panel towards the lead panel to view the vertical gap between the interlockers. Make final roller adjustments so the gap is consistent from top to bottom of the panel. See Fig. 7.2.

Step 7 - Intermediate Panel Installation

Fig. 7.3

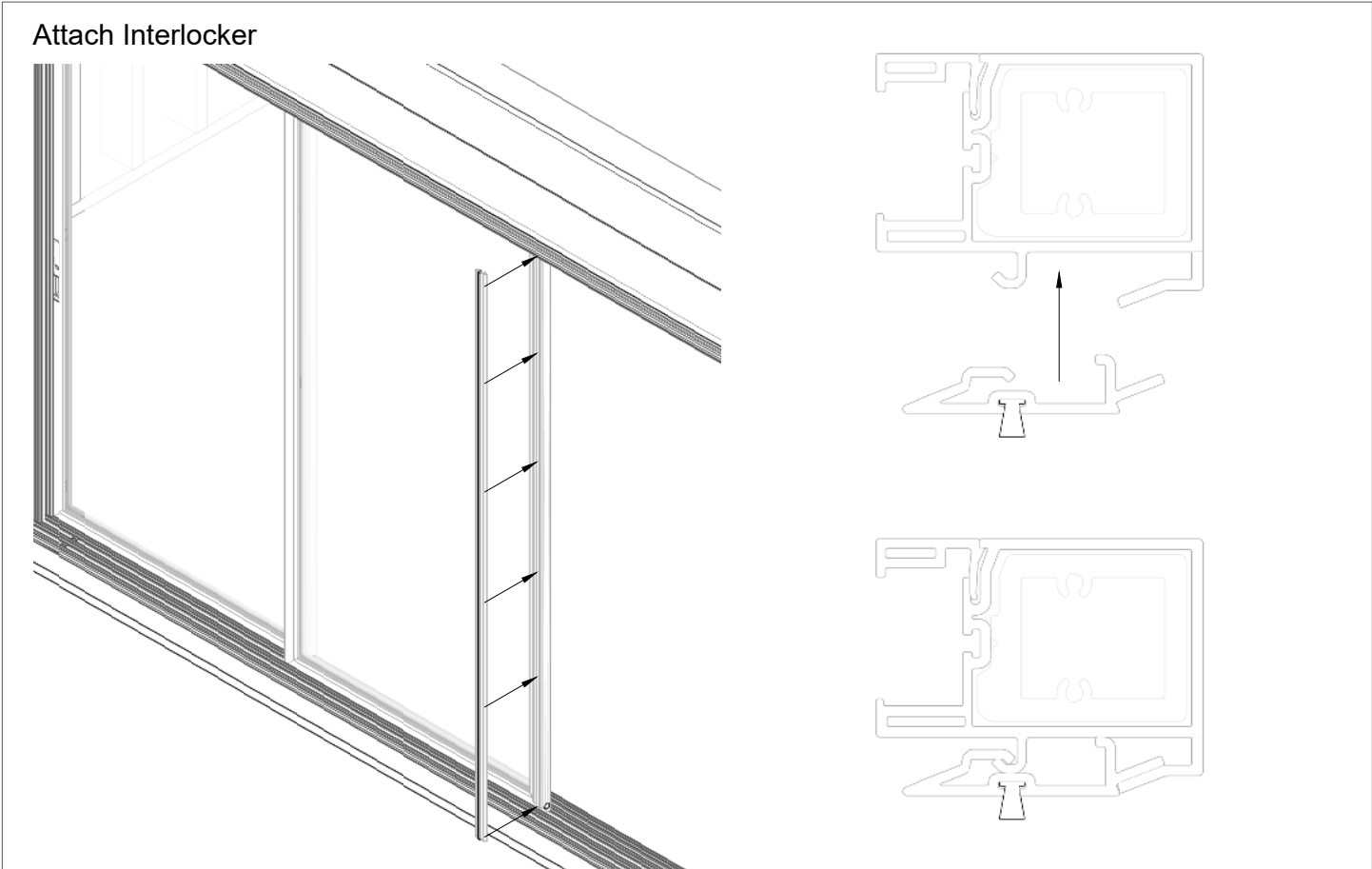

d. Attach the interlocker. See Fig. 7.3.

Step 7 - Intermediate Panel Installation

Fig. 7.4

Slide Panel between Interlockers to confirm smooth operation

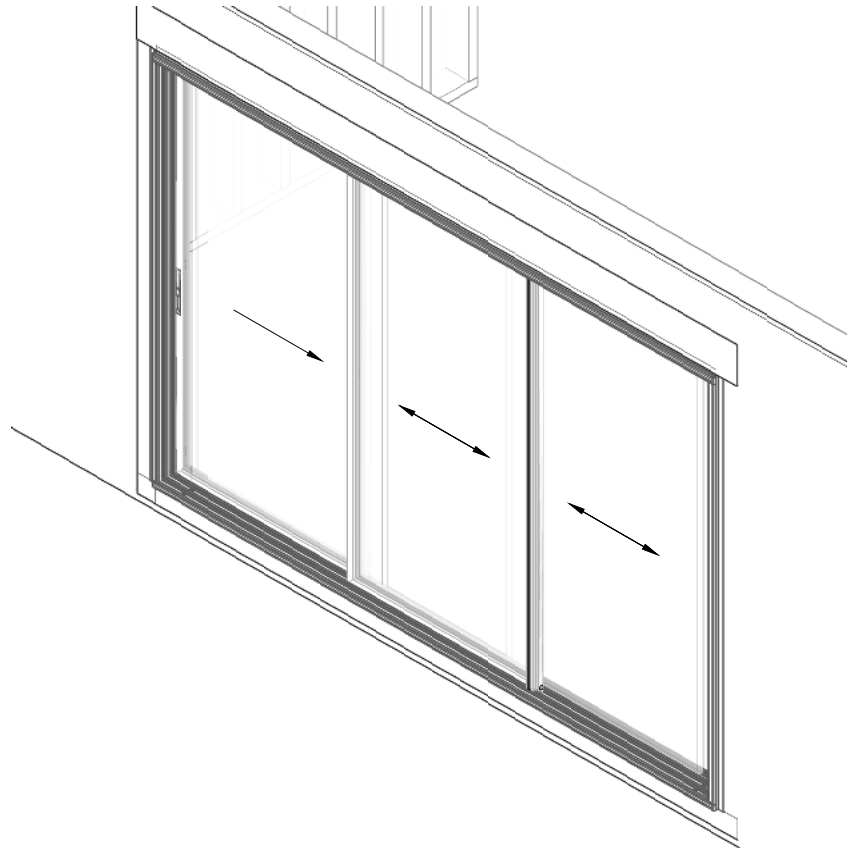

- e. Slide panel full width to confirm smooth operation. See Fig. 7.4.

Step 8 - Fixed Panel Installation

Fig. 8.1

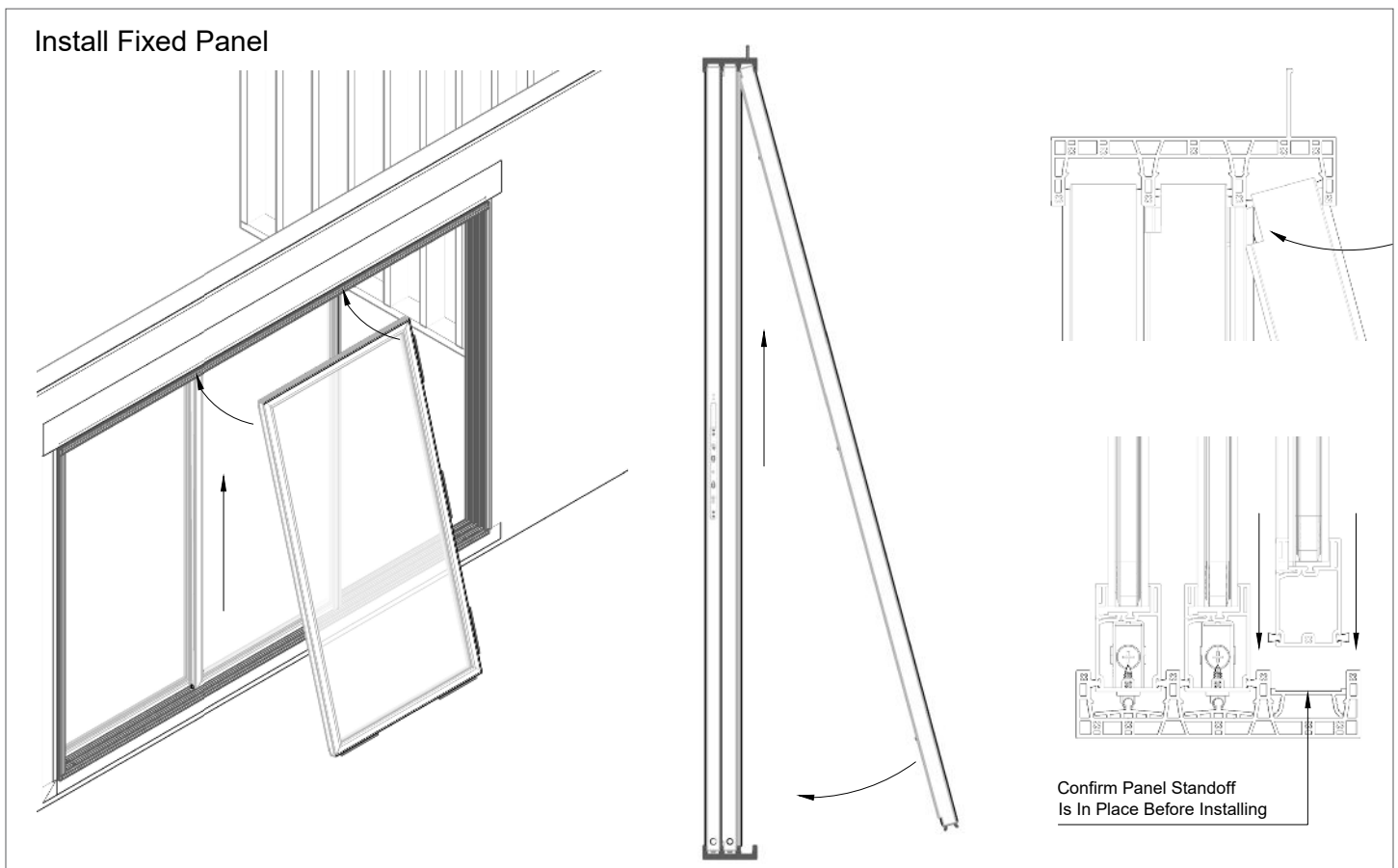

- a. Locate the fixed panel.
- b. From the outside of the building, with the glazing stop to the inside and interlocker overlapping the intermediate panel, lean the top of the panel in and insert it into the exterior head track and lower it onto the threshold. See Fig. 8.1.
- c. Close and lock the door.
NOTE: this is a very important step.
- d. Using the ball of your foot, push fixed panel all the way into the fixed jamb.

Step 8 - Fixed Panel Installation

Fig. 8.2

Predrill and anchor Fixed Panel from the interior side of the door at all 3 locations

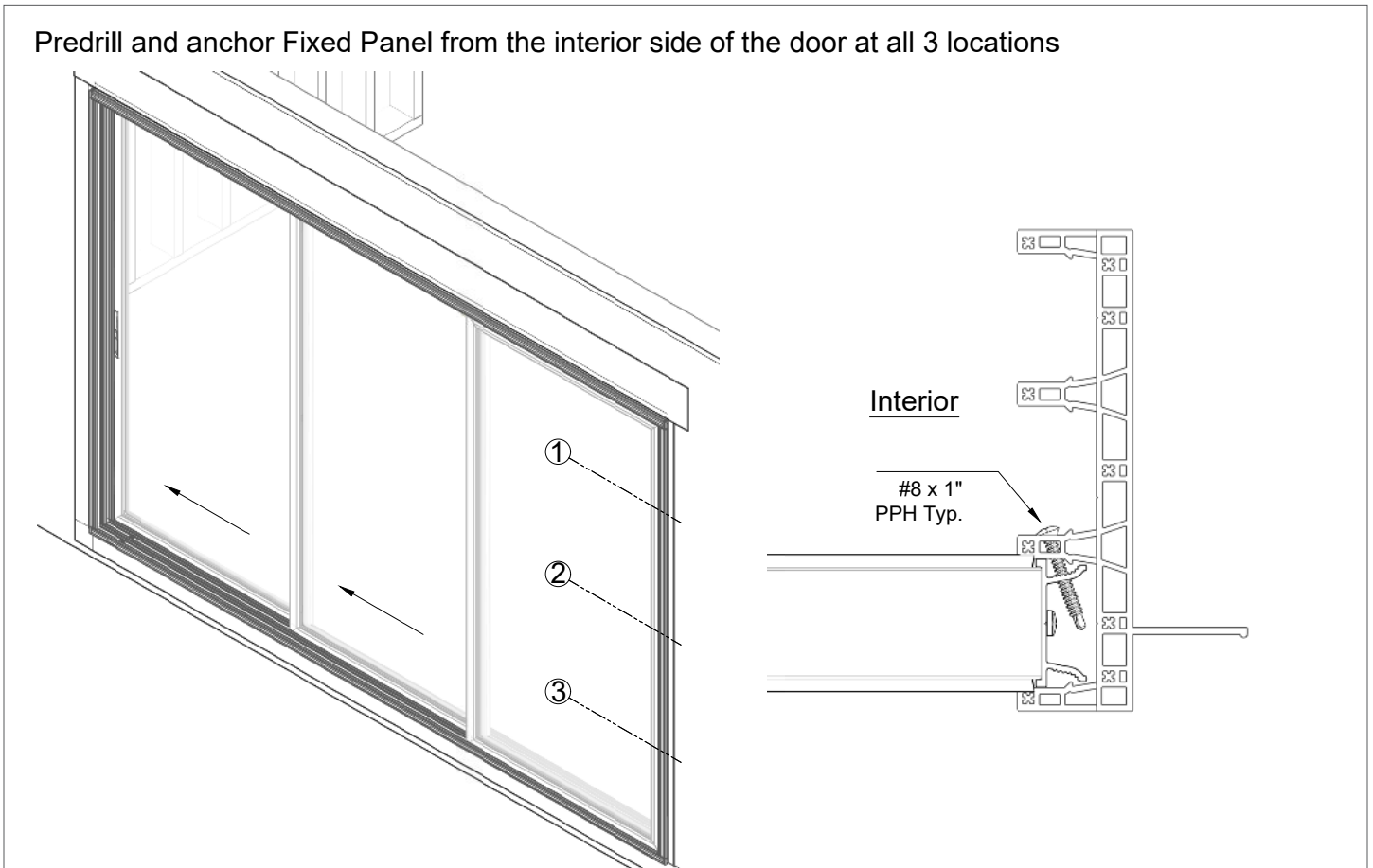

e. Predrill and anchor fixed panel. See Fig. 8.2.

Step 8 - Fixed Panel Installation

Fig. 8.3

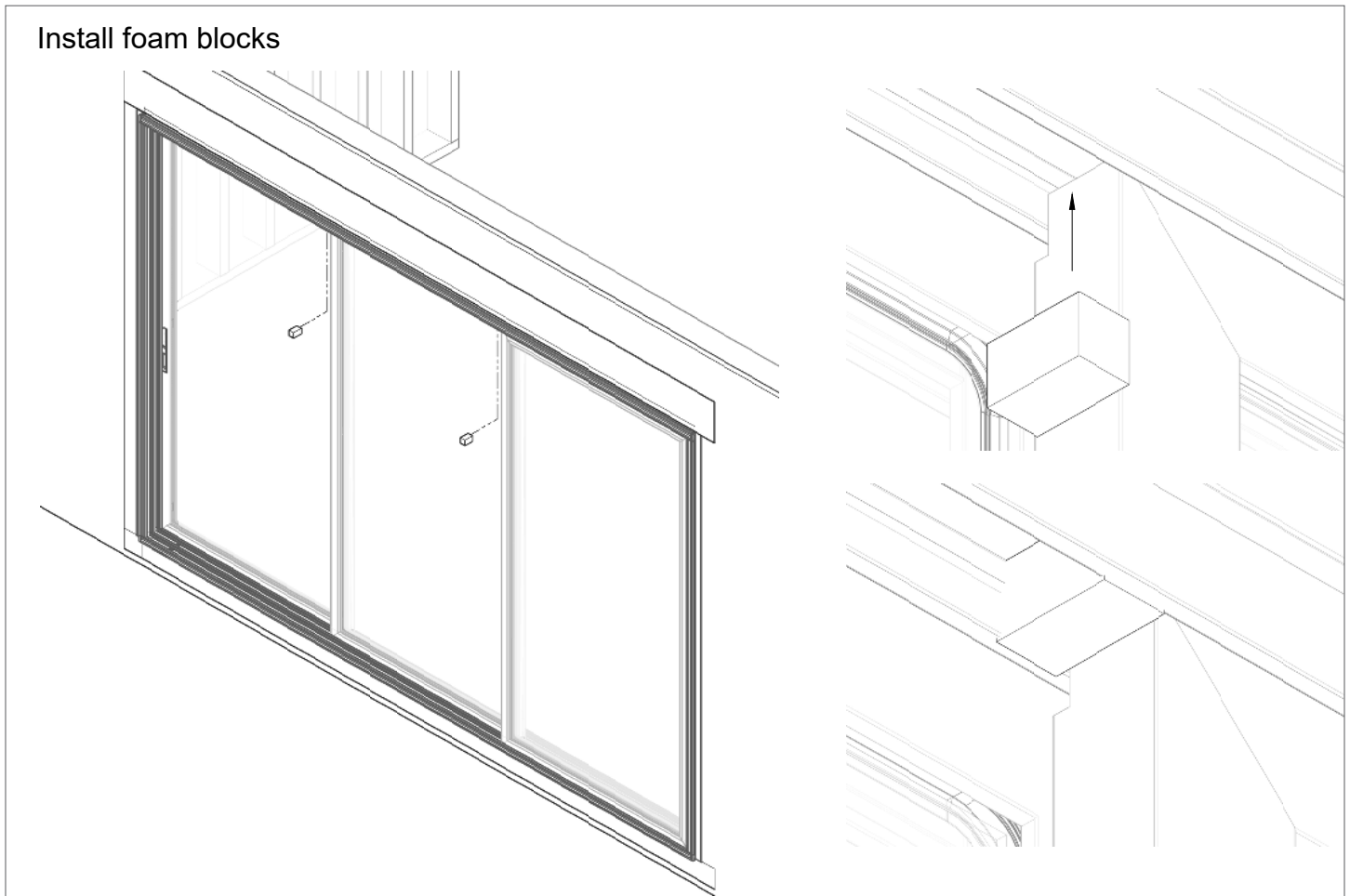

- f. Install foam blocks at intermediate and fixed panels. Use a dot of silicone to hold in place. See Fig. 8.3.

Step 9 - Sill and Jamb Cover Installation

Fig. 9.1

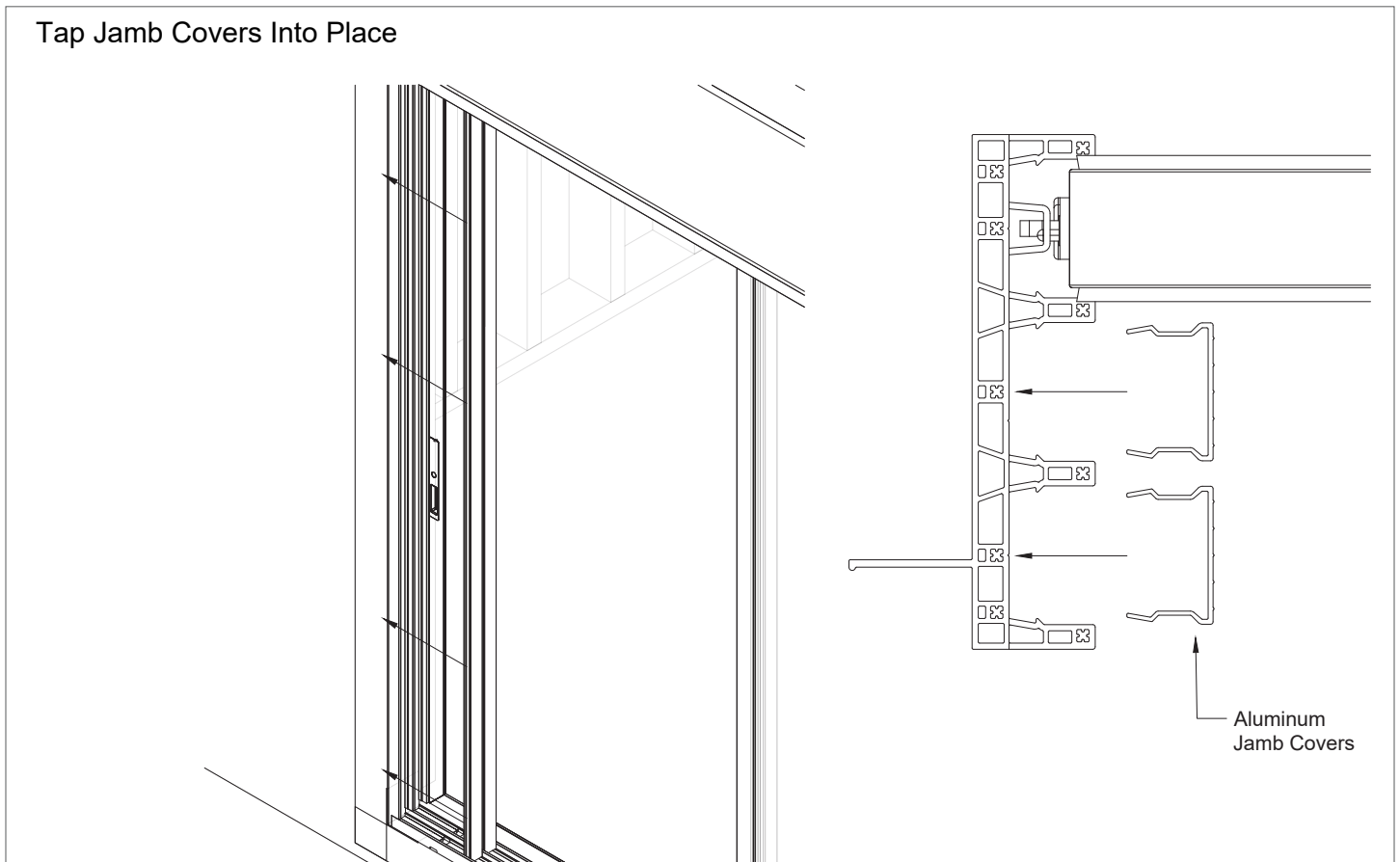

- a. Using a rubber mallet and plastic block, tap jamb covers into place. See Fig. 9.1.

Step 9 - Sill and Jamb Cover Installation

Fig. 9.2

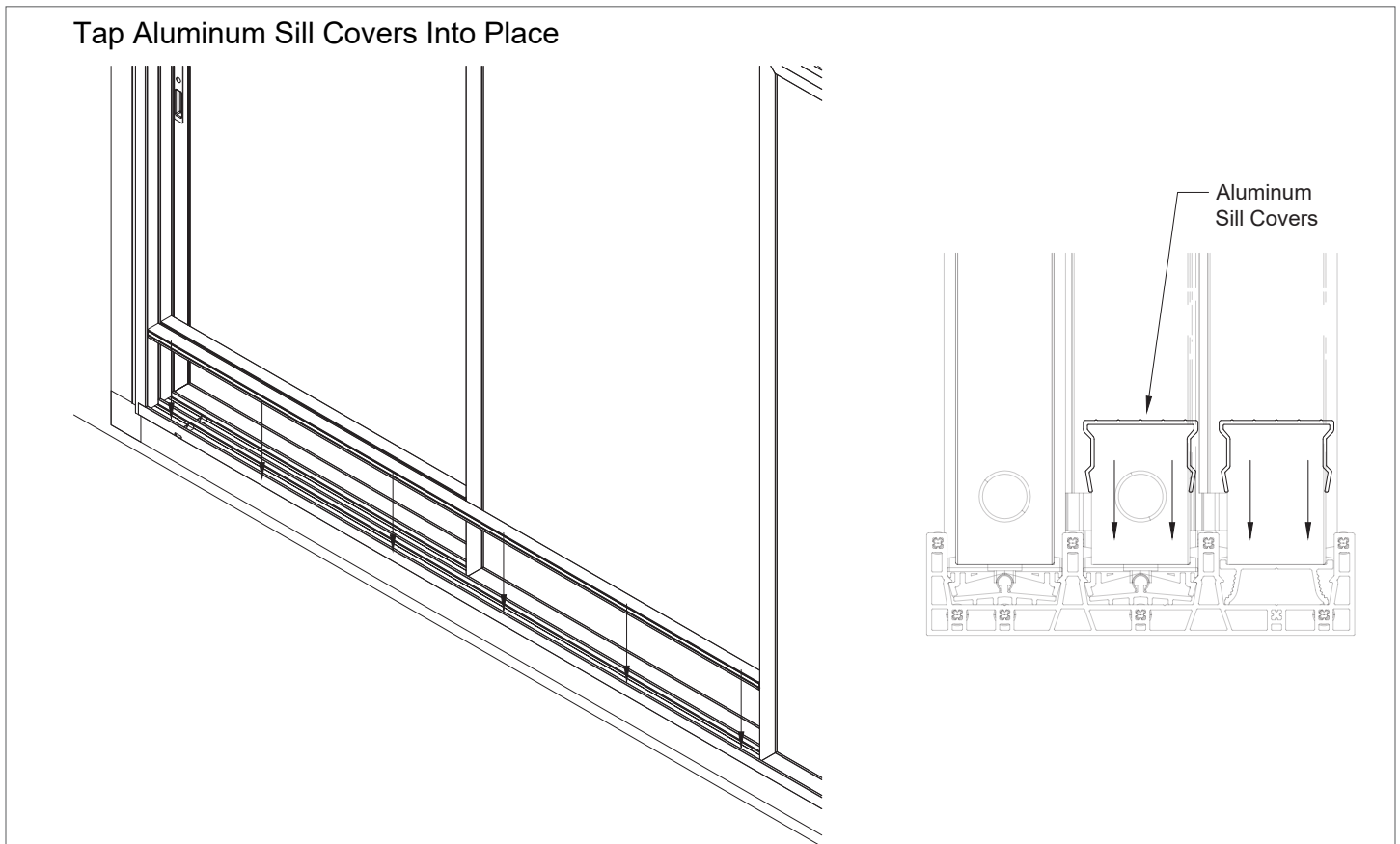

- b. Using a rubber mallet, tap sill covers into place. See Fig. 9.2.

Step 9 - Sill and Jamb Cover Installation

Fig. 9.3

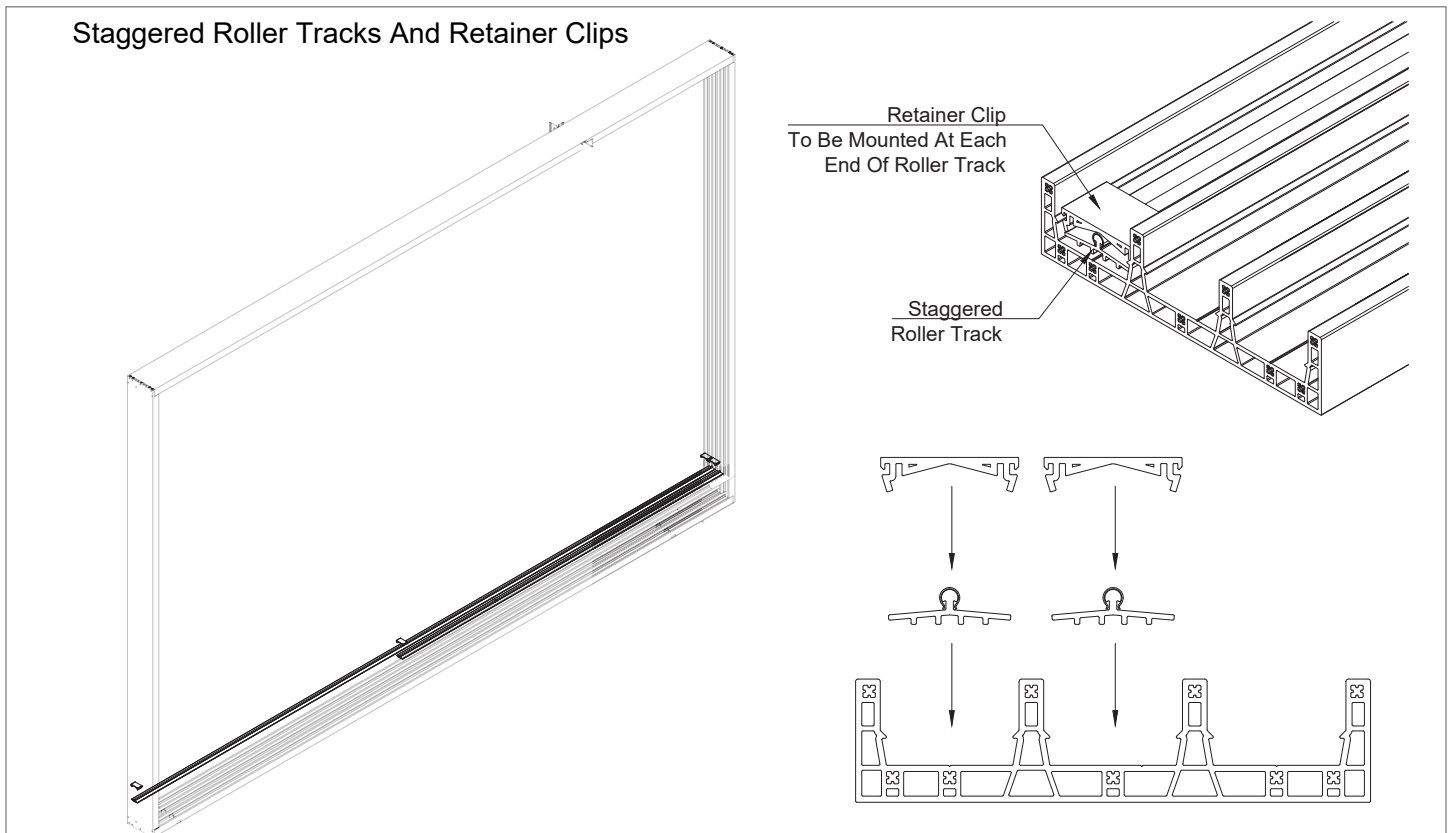

- c. Install retainer clips onto each end of the tracks. See Fig. 9.3.
- d. Confirm operation of the door and lock.
NOTE: this is a very important step.

The door installation is complete.



Volume Program

westernvolumeprogram.com | 877-268-1300
2200 E. Riverview Dr., Phoenix, AZ 85034